



**Design Guide for
Combined Charging System V7
2019-05-08**

Agenda

1 Introduction

2 Illustration of Supply Sequence

3 Illustration of Pulse Width Modulation

4 Illustration of SLAC Sequence

5 Illustration of High Level Communication

6 Potential failures within charging sequence (DINSpec 70121 implemented)

7 Safety Concept for Potential Failures within Supply Sequence

8 Additional key points for EVSE's

9 Relevant Standards

Combined Charging System - Introduction

Combined Charging System

The Combined Charging System is a universal charging system for electric which integrates all established AC charging solutions with ultra-fast DC charging in a single system. Only one charging interface will be required at the vehicle for single-phase AC charging, fast three-phase AC charging as well as ultra-fast d.c. charging at home or public stations.

The Combined Charging System enhances today's regional solutions towards one global integrated system. The Combined Charging System represents the future of fast charging and maximizes the integration of electric vehicles into future smart grids.

The Combined Charging System is an open international standardized system.

Disclaimer

Only public available Standards and Specification published by ISO/IEC and the relevant national Standard Bodies have to be used for product development.

The content of this Design Guide is not binding nor can be exclusively used as basis for product development.

As some standards for the Combined Charging System are not finalized yet (status IS), the relevant standards for the Implementation of the Combined Charging System is organized by the Combined Charging System Specification.

The Design Guide is a simplified training guide which enables the reader to develop a fundamental understanding for the Combined Charging System. The Guide explains and clarifies the system architecture, system activity, charging communication and safety measures of the Combined Charging System. These information are based on relevant Standards and are therefore a starting point for station manufacturers and operators as well as suppliers.

Contents Design Guidance	Simplified Charging Architecture and System Activity	<ul style="list-style-type: none">▪ The System Architecture of the Combined Charging System serves for a systematic definition of the system activity. For each charge state the active electric components are identified and highlighted in the architectural diagram. The aspects covered include characteristics and operating conditions of the supply device and the connection to the vehicle.
	Description of Safety Concept	<ul style="list-style-type: none">▪ The Safety Concept describes the advanced safety functionalities of the Combined Charging System to avoid potential failures for DC Charging of EVs and to reduce main risks through defined exit strategies.
	Illustration of PWM and High Level Communication	<ul style="list-style-type: none">▪ The illustration of Pulse Width Modulation and High Level Communication is a clarification of function and the preconditions for the communication between the EV and the DC Supply.
	Standards	<ul style="list-style-type: none">▪ The listed standards are the basis for the Design Guide and providing general and basic requirements for DC EV charging stations for conductive connection to the vehicle. Also some major supplier for charging components and equipment are listed.

Agenda

1 Introduction

2 Illustration of Supply Sequence

3 Illustration of Pulse Width Modulation

4 Illustration of SLAC Sequence

5 Illustration of High Level Communication

6 Potential failures within charging sequence (DINSpec 70121 implemented)

7 Safety Concept for Potential Failures within Supply Sequence

8 Additional key points for EVSE's

9 Relevant Standards

Illustration of charging sequence with a simplified architecture on system level

The charging sequence and its related system activities are specified in a detailed but highly compressed manner in IEC 61851-23, Annex CC.

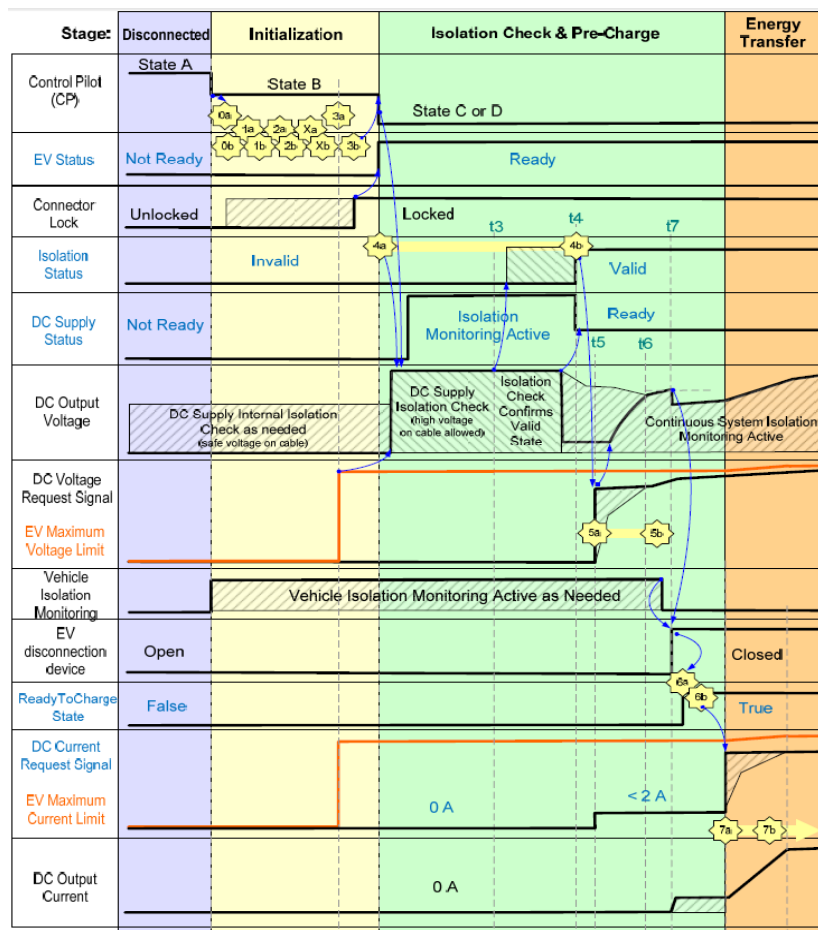

61851-23 © IEC:201X

- 62 -

61851-23 © CEI:201X

Table CC.3 - Sequence description for Normal Start Up

	Description
(t0)	<ul style="list-style-type: none"> Vehicle connector is plugged into vehicle inlet which changes CP state from A to B.
(t0 → t1)	<ul style="list-style-type: none"> High level communication (PLC) starts and handshaking with exchange of charging parameters takes place. D.C. supply checks if d.c. output voltage is less than 60 V and terminates supply session if 60 V is exceeded.
(t1)	<ul style="list-style-type: none"> EV sends its maximum limits (amongst other parameters) for d.c. supply output current and voltage with <3a>.
(t1 → t2)	<ul style="list-style-type: none"> EV locks vehicle connector in its inlet. Maximum values of the d.c. supply are responded to the EV with <3b>. D.C. supply can check internal isolation as long as no voltage is applied to the connector. If EV and d.c. supply are not compatible, then the vehicle will not go to Ready, and will transition to step t16 in the normal shutdown sequence.
(t2)	<ul style="list-style-type: none"> EV changes CP state from B to C/D by closing S2 and sets EV status "Ready", which ends initialization phase.
(t2 → t3)	<ul style="list-style-type: none"> EV requests cable and isolation check by <4a> after connector lock has been confirmed. D.C. supply starts checking HV system isolation and continuously reports isolation state by <4b>.
(t3)	<ul style="list-style-type: none"> D.C. supply determines that isolation resistance of system is above 100 kΩ (cf. CC.5.1).
(t3 → t4)	<ul style="list-style-type: none"> After having successfully finished the isolation check, d.c. supply indicates status "Valid" with subsequent message <4b>
(t4)	<ul style="list-style-type: none"> D.C. supply status changes to "Ready" with Cable Check Response <4b>
(t5)	<ul style="list-style-type: none"> Start of pre-charge phase with EV sending Pre-Charge Request <5a>, which contains both requested DC current <2A (maximum inrush current acc. to CC.6.2) and requested DC voltage.
(t5 → t6)	<ul style="list-style-type: none"> D.C. supply adapts d.c. output voltage to requested value in <5a> while limiting current to maximum value of 2 A (maximum inrush current according to CC.6.2)

➤ To make the IEC 61851-23 standard description easier to understand, the following pages provide a step-by-step insight into the charging sequences by applying a simplified system architecture.

Illustration of charging sequence with a simplified architecture on system level

The simplified charging architecture and system activity allows a systematic description of the charging sequences and the high level communication of the Combined Charging System.

Description

- Based on a simplified architecture on system level the different sequences with the complete set of functions of the combined charging system will be explained.
- The following functional overview is a complete description of all charging sequences. It contains
 - the system operation behavior and its reflection to high-level functions
 - for each sequence the identified and highlighted active electric components

Example

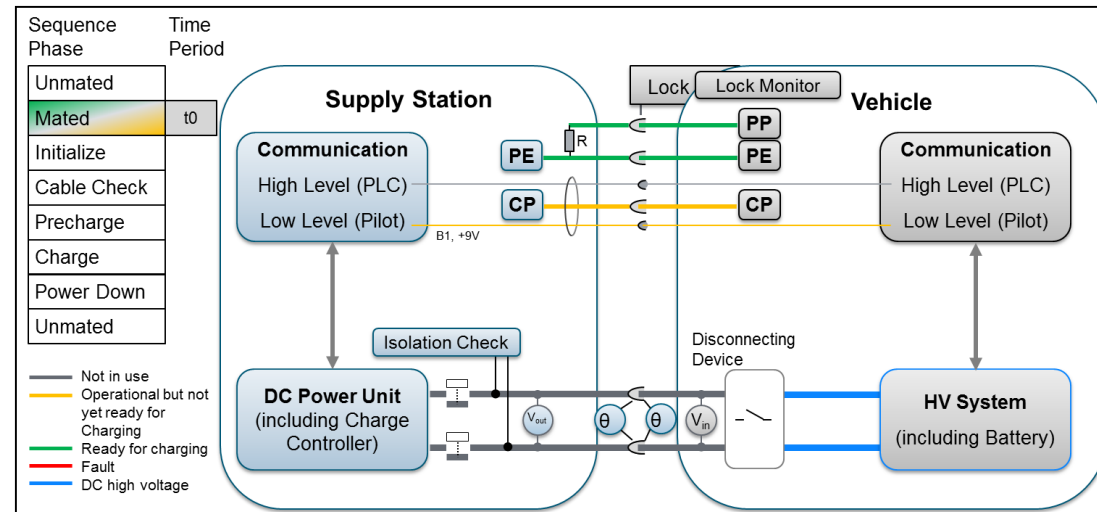

Illustration of charging sequence with a simplified architecture on system level

Unmated

Glossar:

Supply
Infrastructure power supply

Vehicle
Electric Vehicle

PLC
Power Line Communication

PE
Protective Earth

V_{in}
Vehicle Input Voltage Monitoring

V_{out}
Supply Output Voltage Measurement

θ
Temperature

-C / C
Physical / functional connection

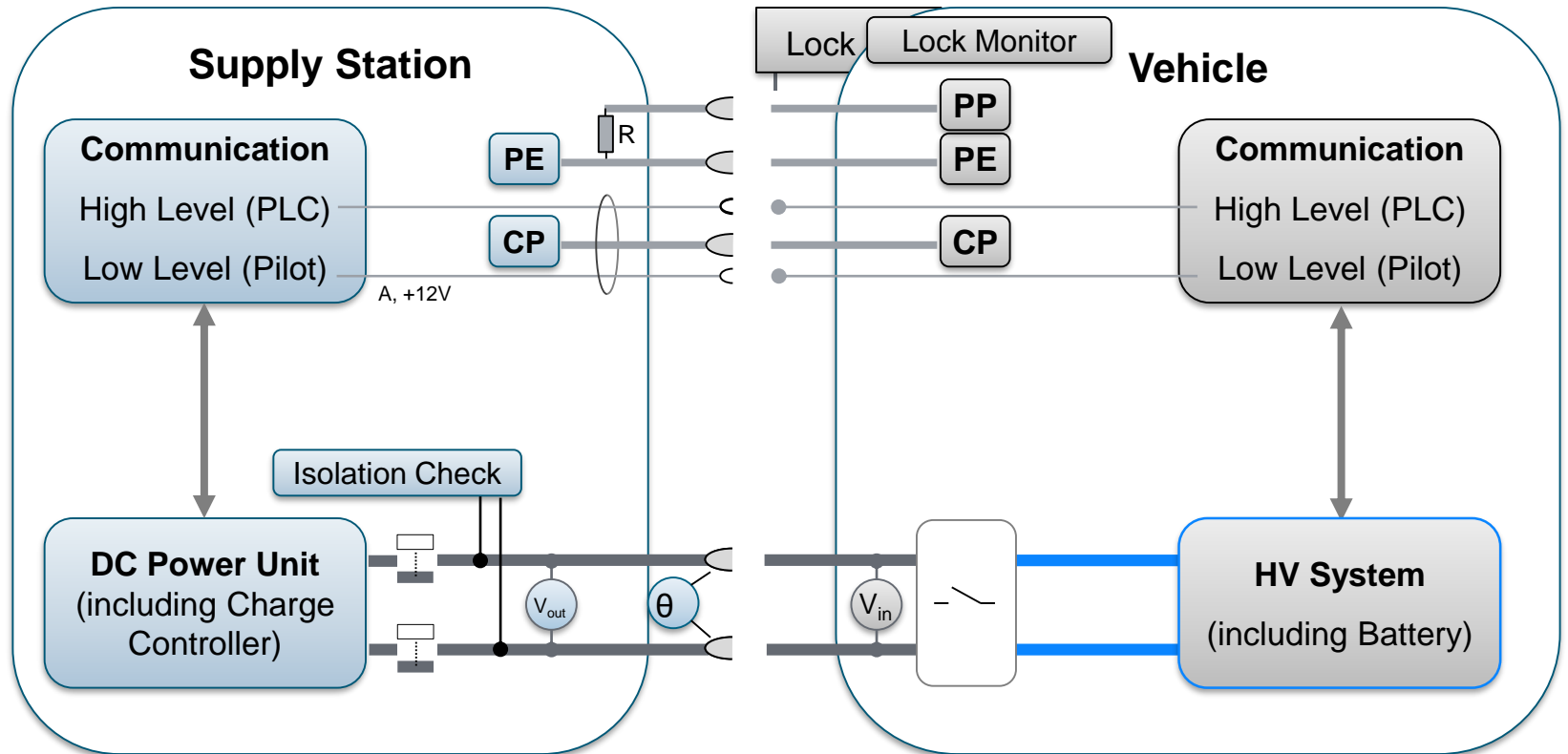

➤ Schematic shows only the relevant physical and functional elements for illustration.

Illustration of charging sequence with a simplified architecture on system level

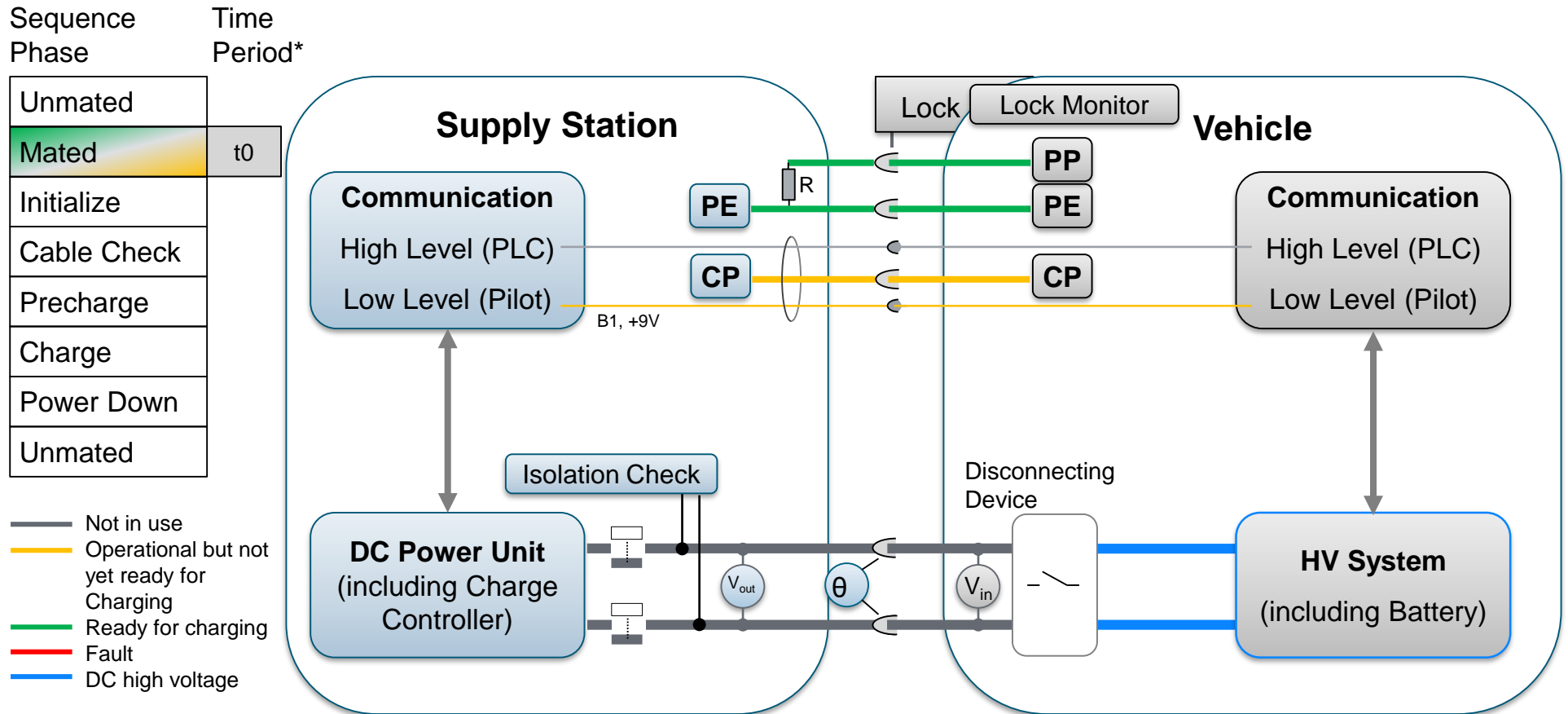

➤ CP enters state B1 instantly with mating. Vehicle is immobilized (PP).

Illustration of charging sequence with a simplified architecture on system level

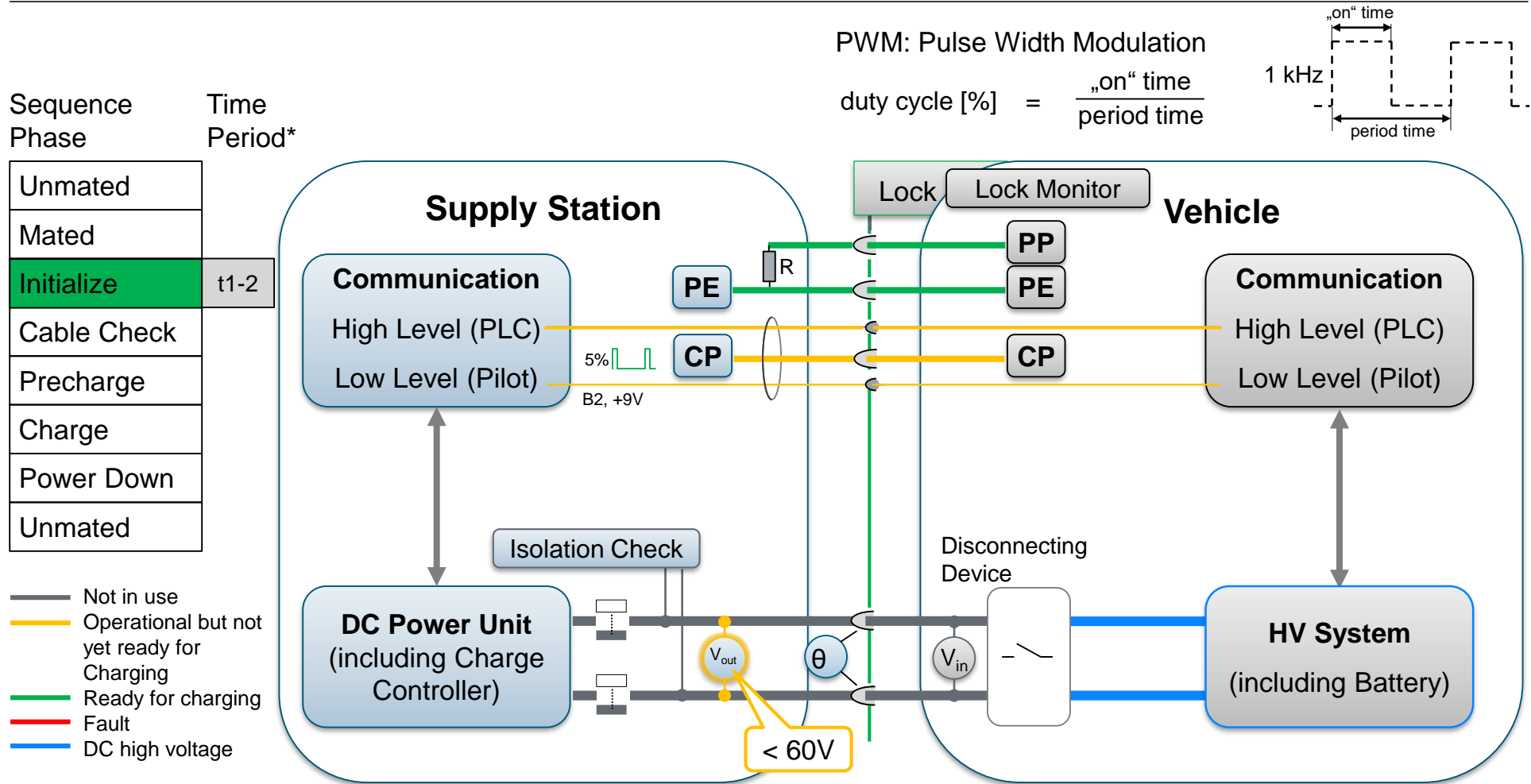

➤ Establish PLC communication: Exchange operating limits and parameters of charging. Shutdown if d.c. Voltage > 60V or incompatibility of EV and d.c. supply is detected.

* According to IEC 61851-23

Illustration of charging sequence with a simplified architecture on system level

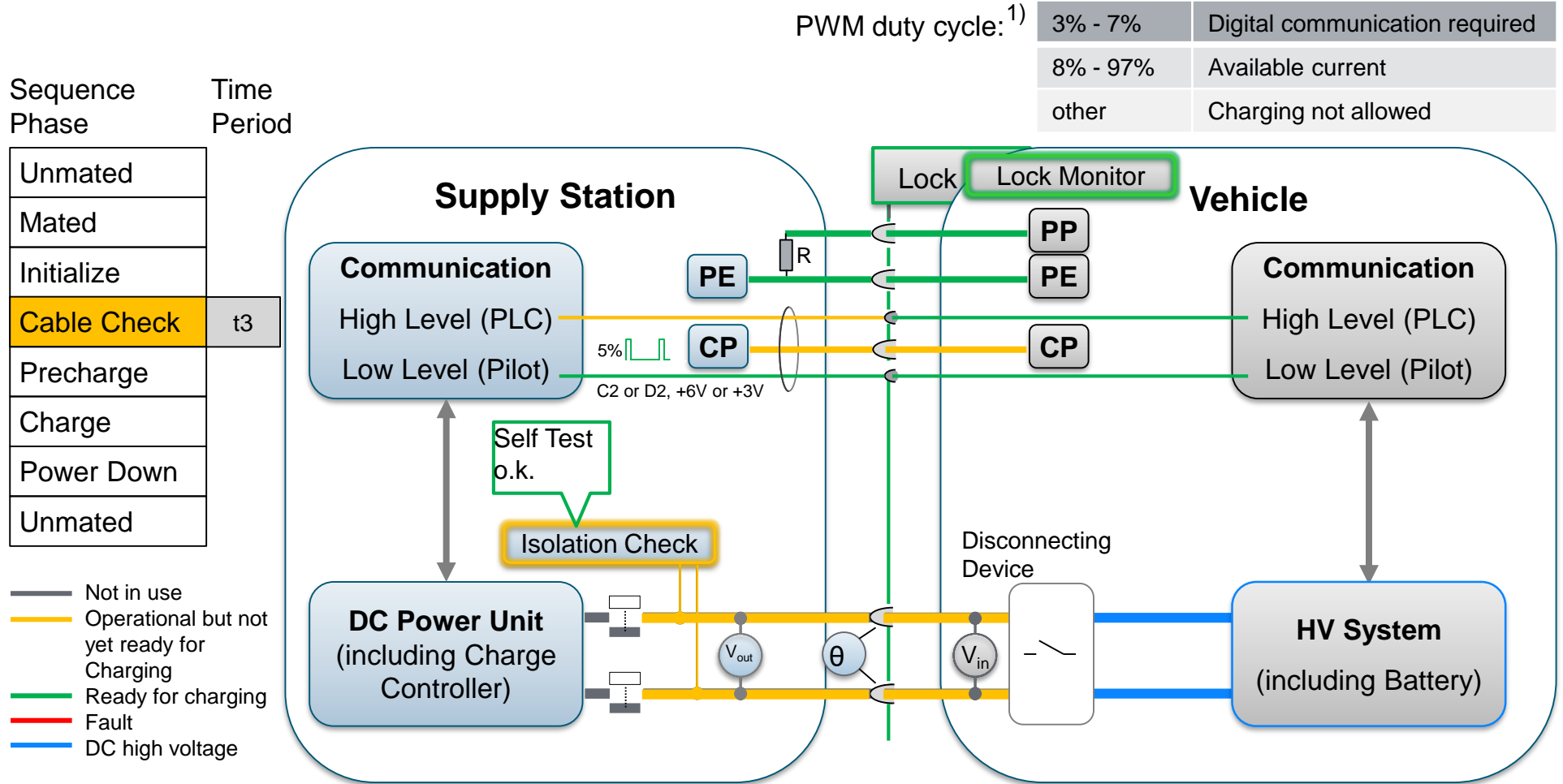

➤ EV changes CP state from B to C/D and sets EV status “Ready”. After connector lock has been confirmed d.c. supply starts checking HV system isolation and continuously reports isolation state.

¹⁾ IEC61851-1, Table A3.9

Illustration of charging sequence with a simplified architecture on system level

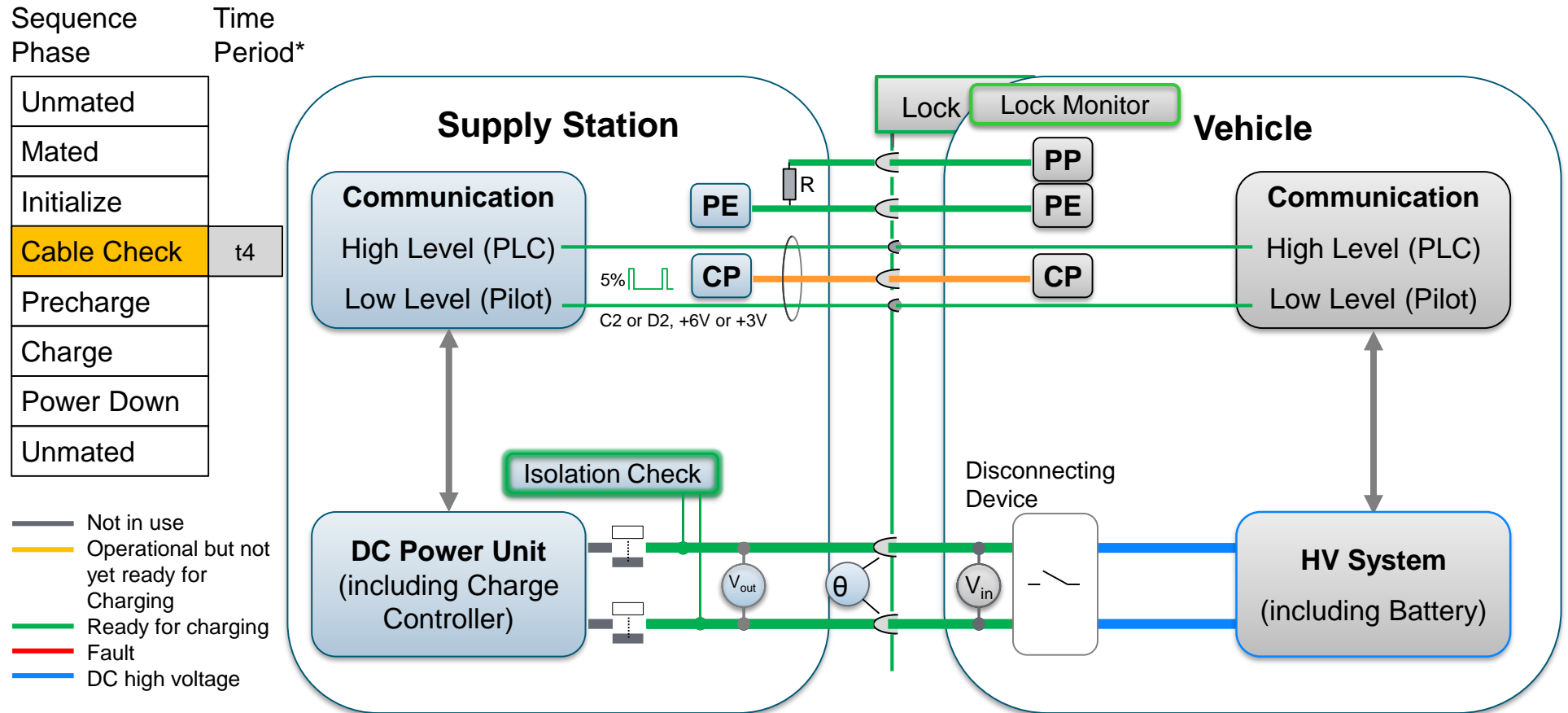

- D.C. supply determines that isolation resistance of system is above 100 kΩ. After successful isolation check, d.c. supply indicates status "Valid" and changes status to "Ready" with Cable Check Response.

Illustration of charging sequence with a simplified architecture on system level

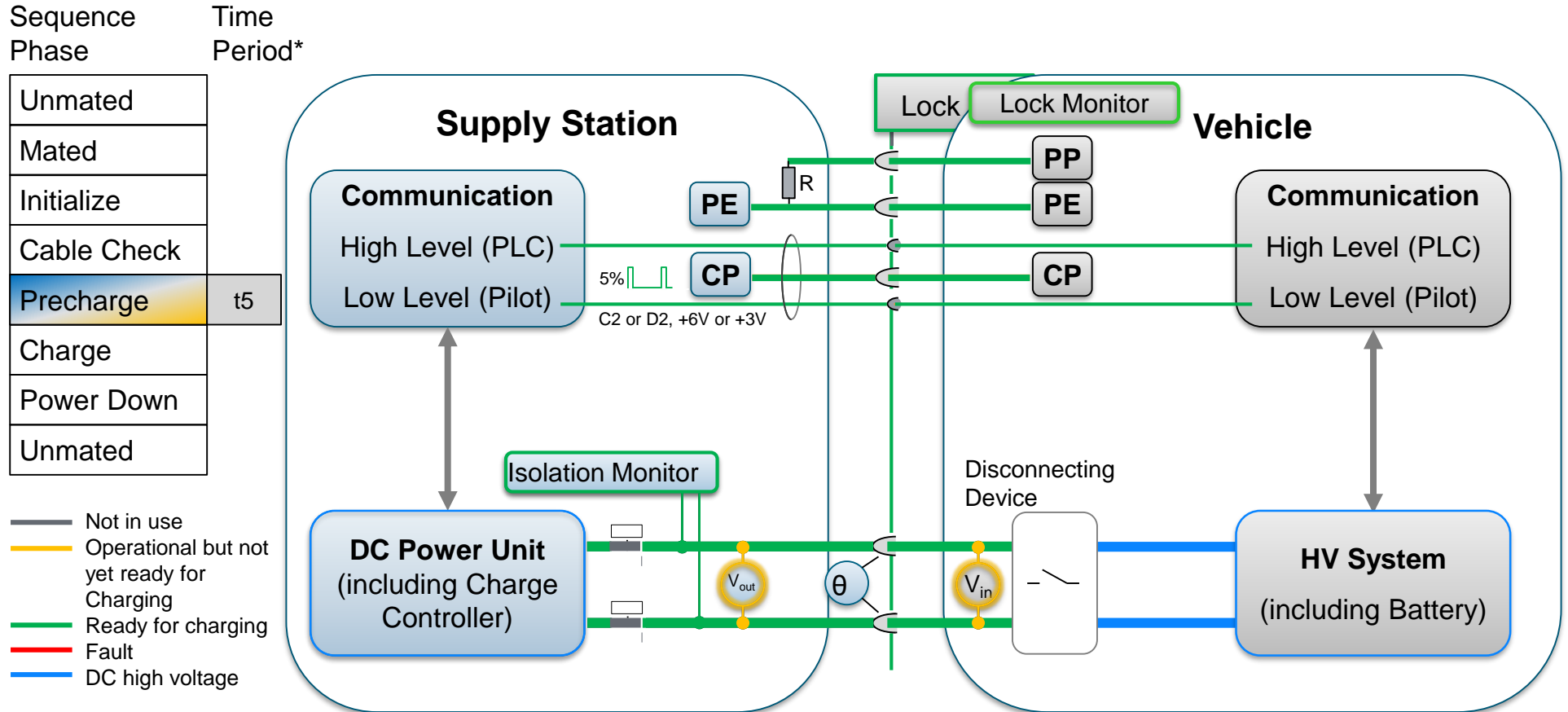

➤ EV sends Pre-Charge Request, which contains both requested d.c. current <2A (maximum inrush current) and requested DC voltage.

* According to IEC 61851-23

Illustration of charging sequence with a simplified architecture on system level

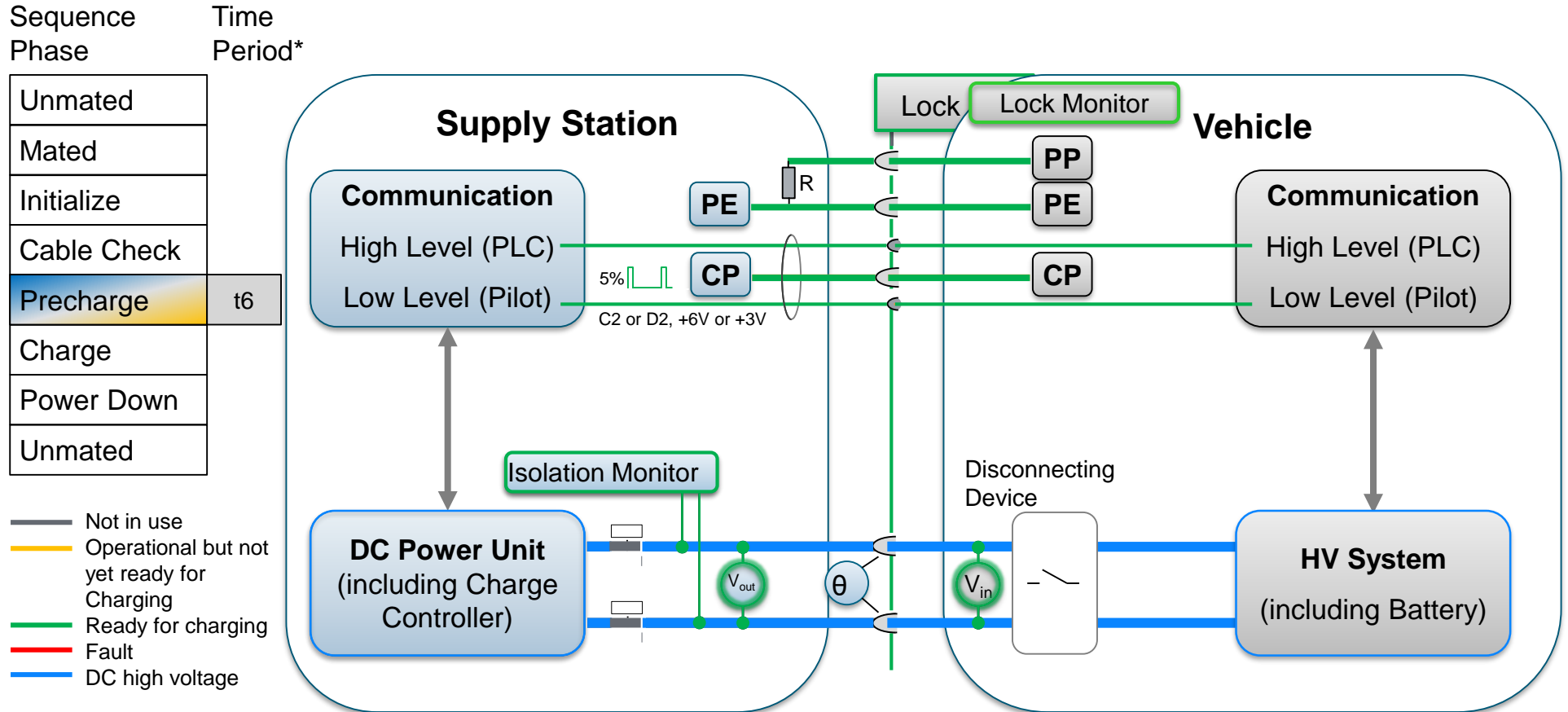

➤ D.C. supply adapts d.c. output voltage within tolerances and limits current to maximum value of 2 A.

* According to IEC 61851-23

Illustration of charging sequence with a simplified architecture on system level

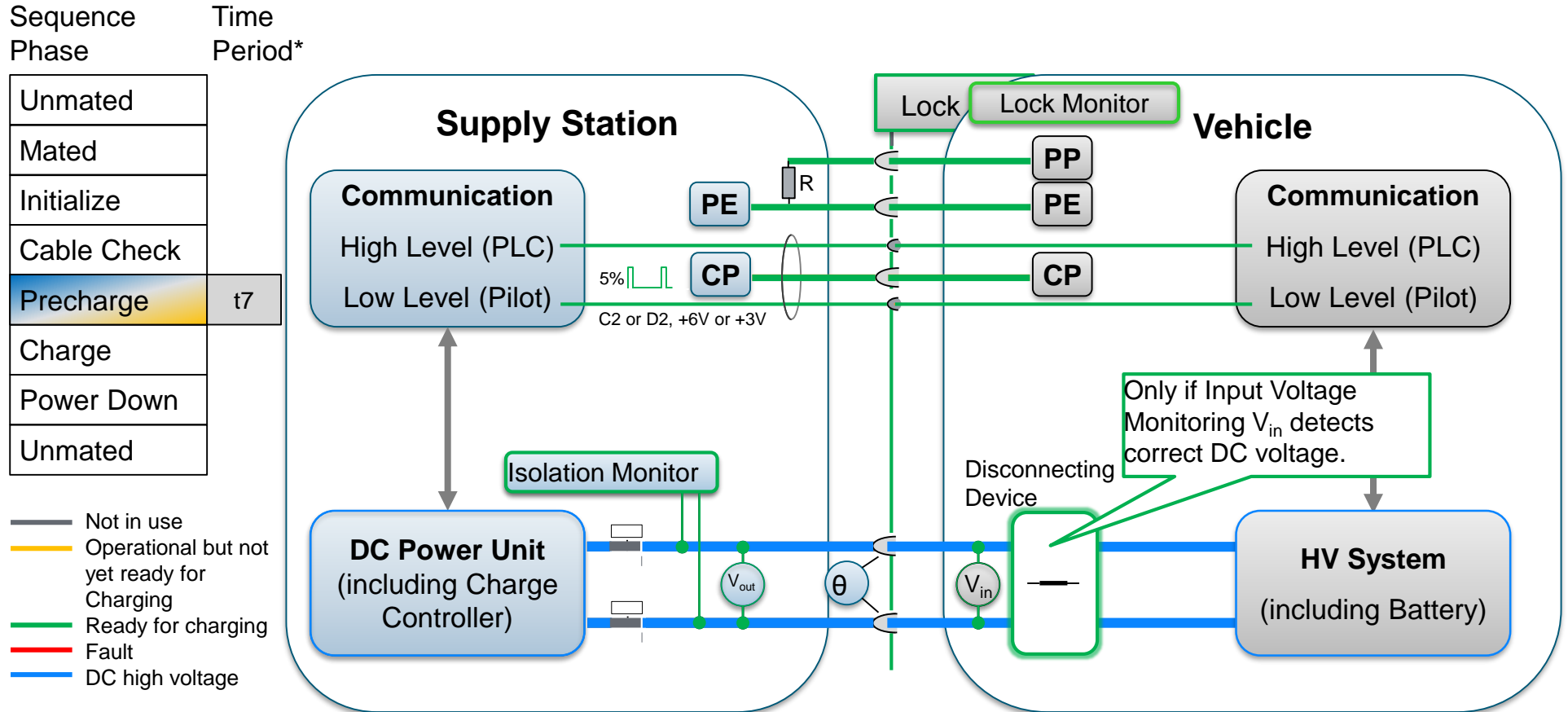

➤ EV closes disconnecting device after deviation of d.c. output voltage from EV battery voltage is less than 20 V.

* According to IEC 61851-23

Illustration of charging sequence with a simplified architecture on system level

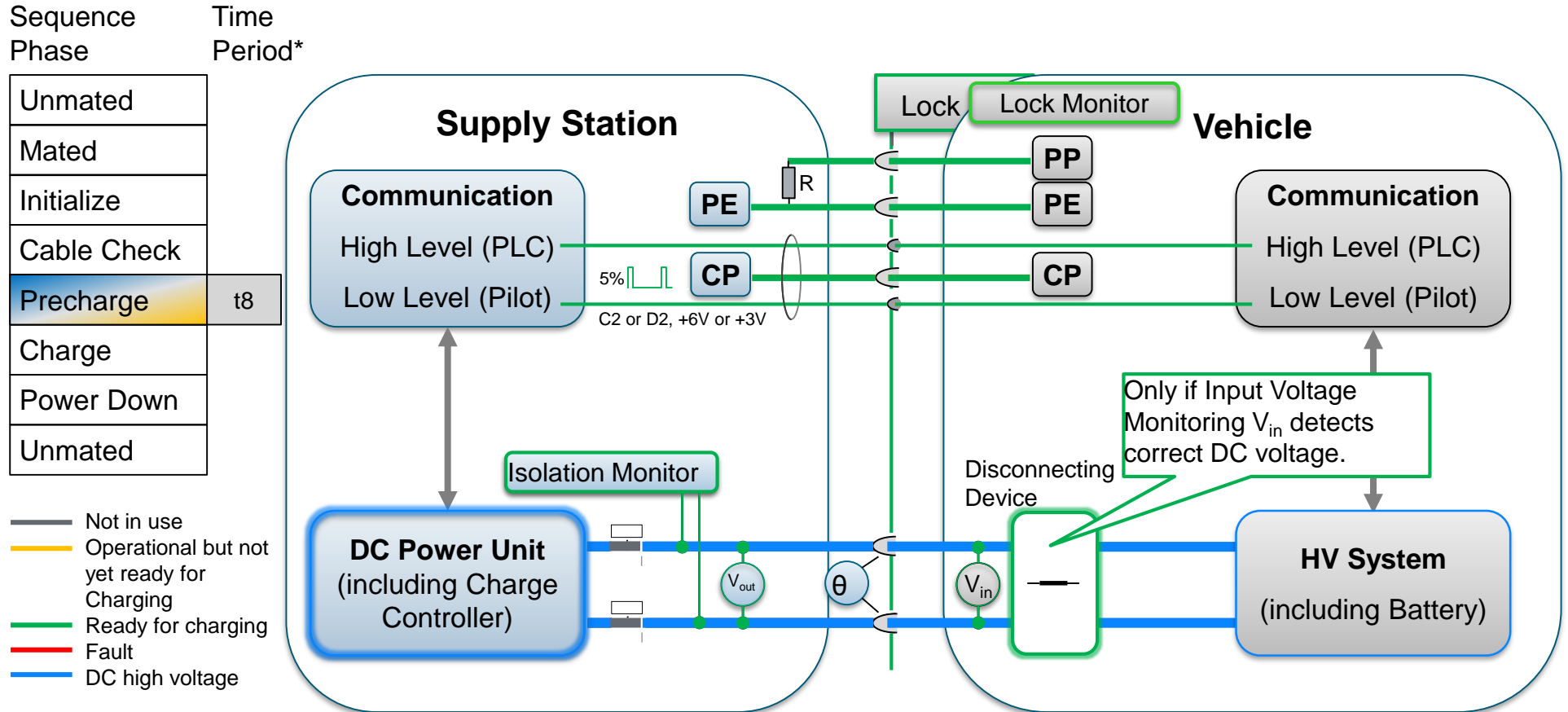

- EV sends Power Delivery Request to enable d.c. power supply output. After d.c. supply gives feedback that it is ready for energy transfer EV sets d.c. current request to start energy transfer phase.

Illustration of charging sequence with a simplified architecture on system level

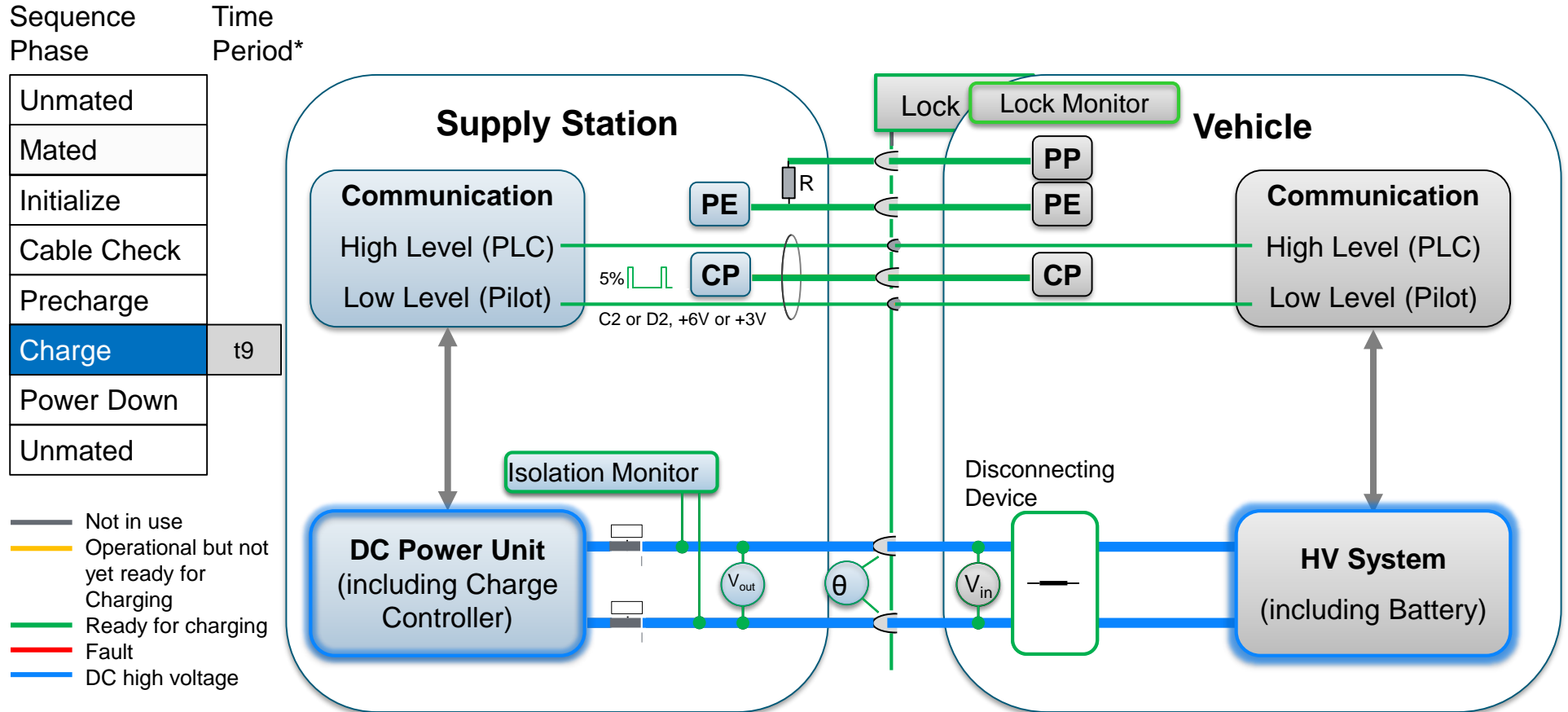

- EV is initiating message cycles by requesting voltage/current. Supply is responding with voltage/current adjustment as well as present limit and status values (voltage, current, isolation, ...).
- Continuous monitoring of lock, isolation, voltage, current and temperature.

Illustration of charging sequence with a simplified architecture on system level

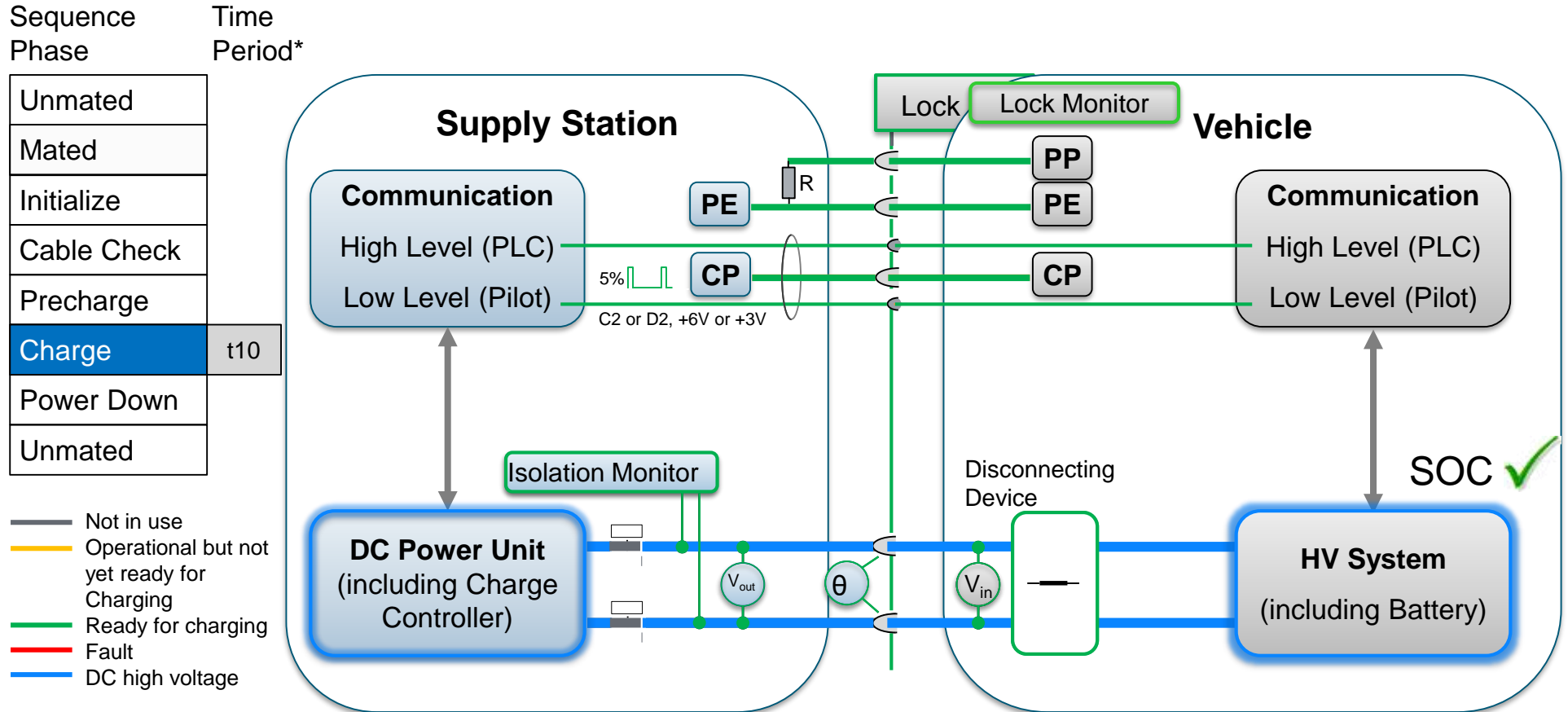

➤ EV reduces the current request to complete the energy transfer. The d.c. supply follows the current request with a time delay and reduces the output current to less than 1A before disabling its output.

* According to IEC 61851-23

Illustration of charging sequence with a simplified architecture on system level

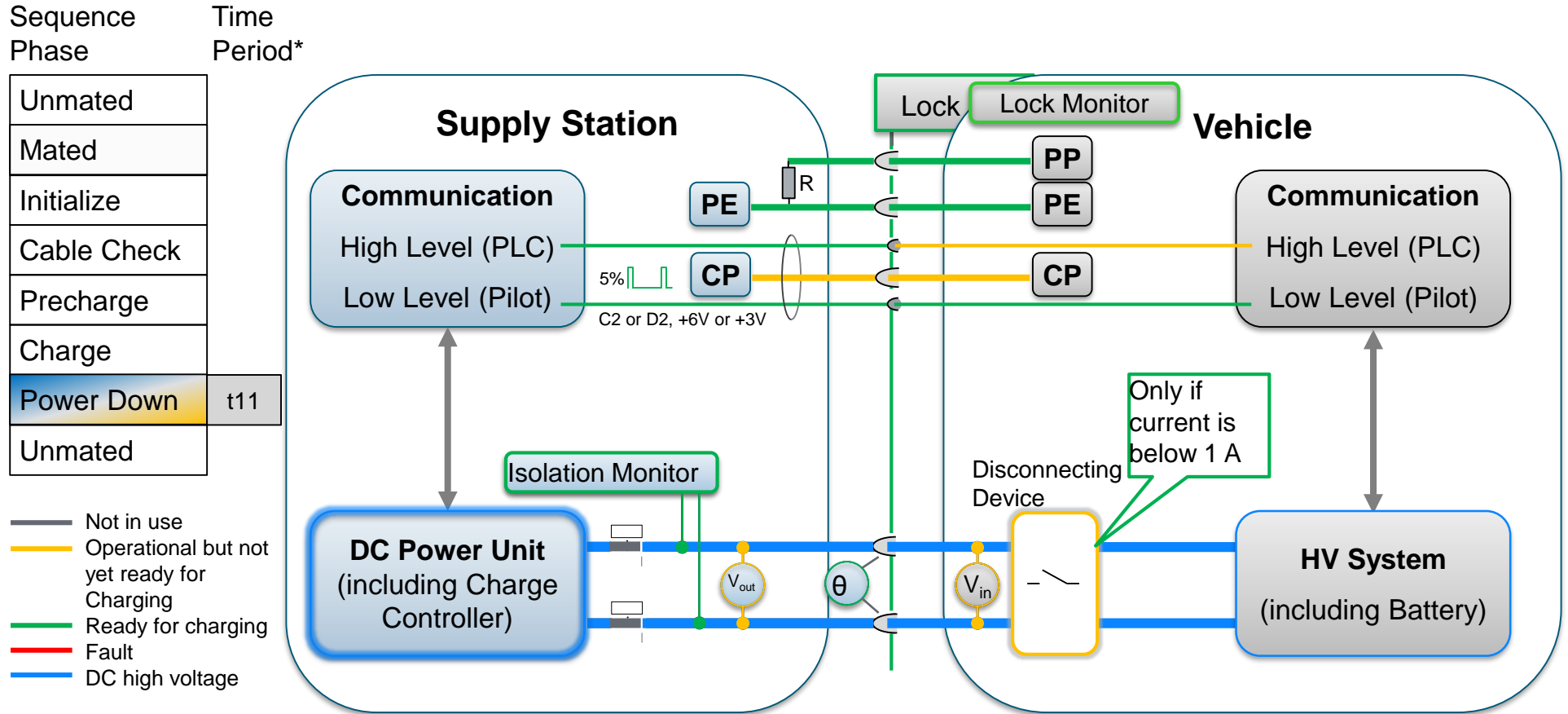

➤ EV sends a message to d.c. supply to disable its power output. After current is below 1 A the EV opens its disconnection device.

* According to IEC 61851-23

Illustration of charging sequence with a simplified architecture on system level

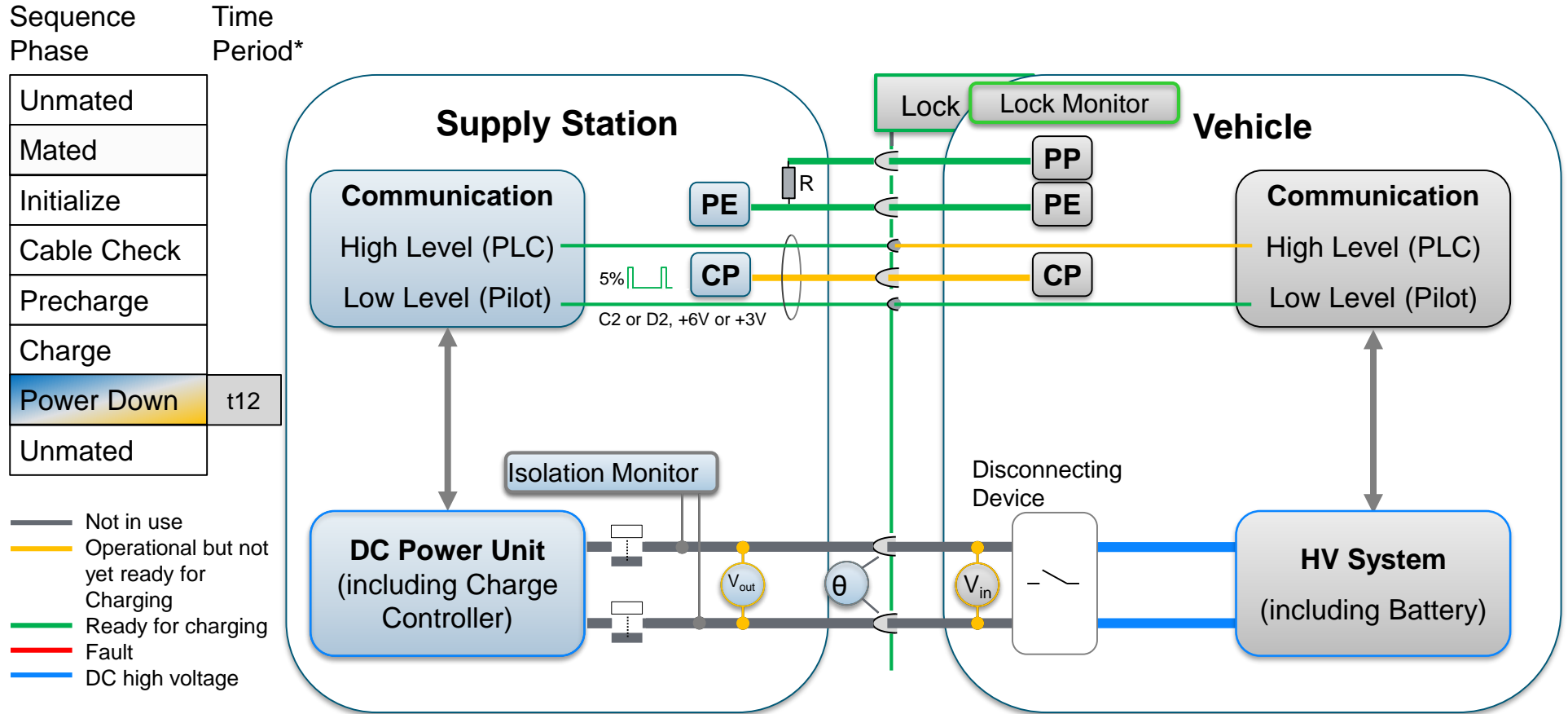

➤ D.C. supply disables its output and opens contactors, if any.

* According to IEC 61851-23

Illustration of charging sequence with a simplified architecture on system level

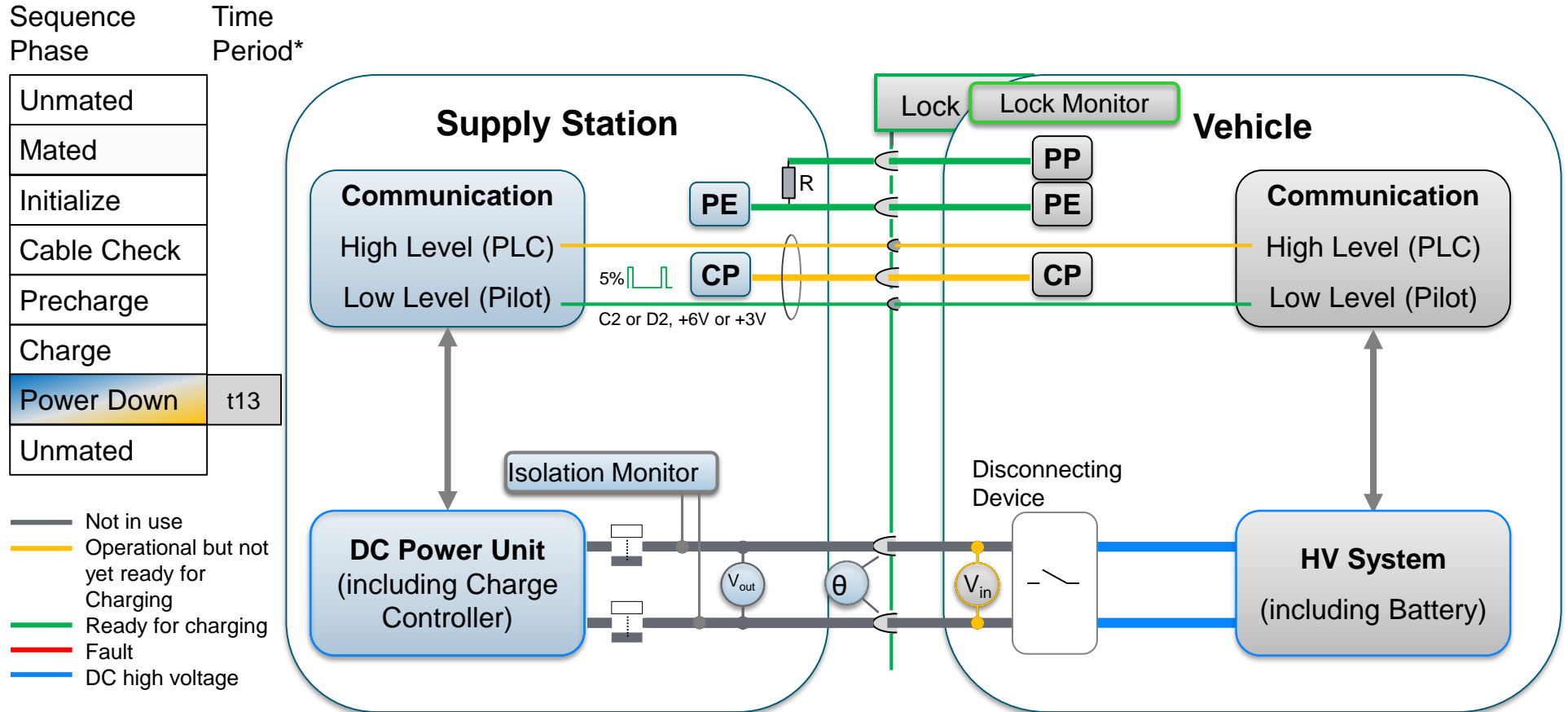

➤ D.C. supply reports status code "Not Ready" with a message to indicate it has disabled its output.

Illustration of charging sequence with a simplified architecture on system level

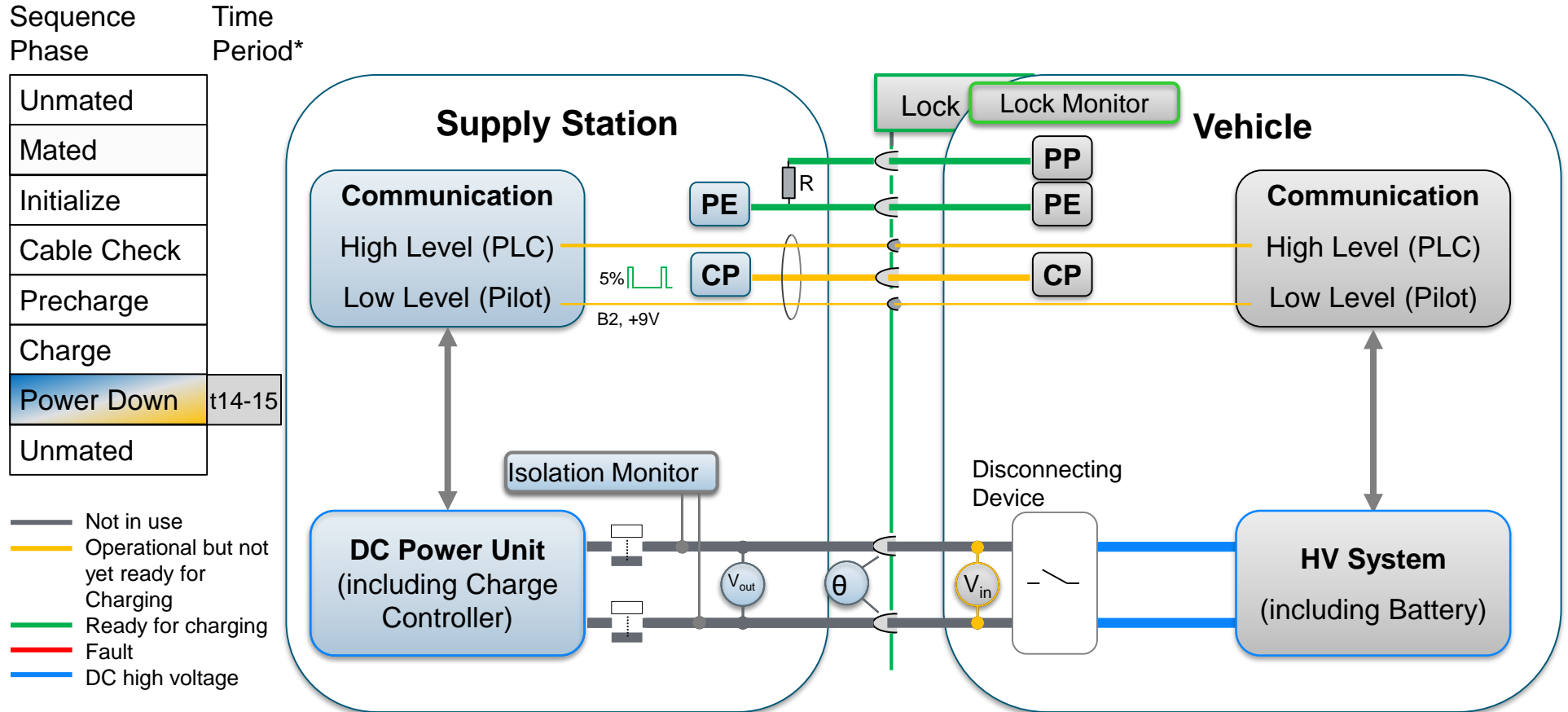

- EV changes CP state to B after receiving message or after timeout. Vehicle may perform welded contactor check (optional).

Illustration of charging sequence with a simplified architecture on system level

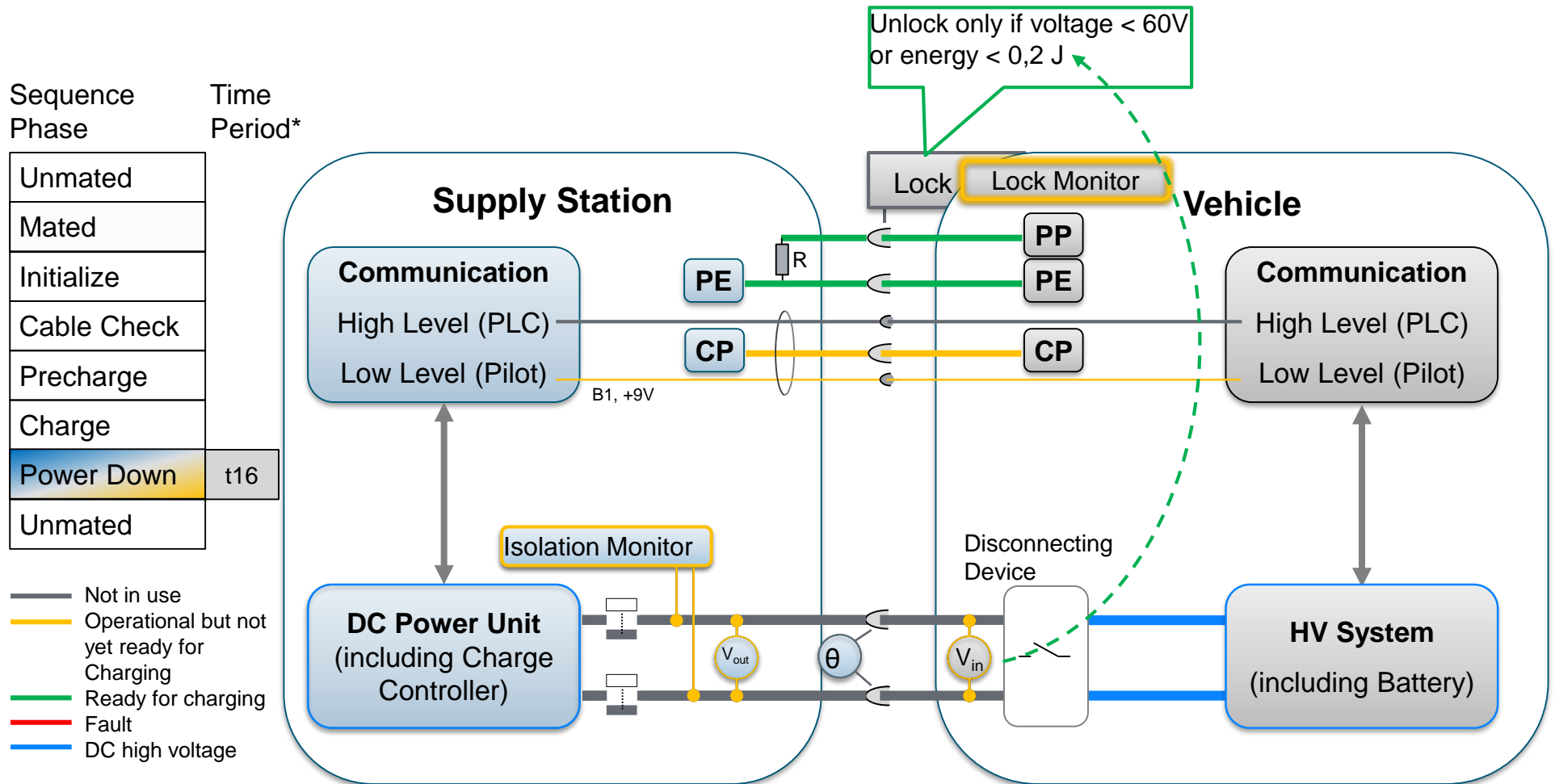

- EV unlocks the connector after d.c. output has dropped below 60 V. The d.c. supply continues isolation monitoring dependant on d.c. supply strategy.
- Session Stop Request with a message and terminates digital communication (PLC).

Illustration of charging sequence with a simplified architecture on system level

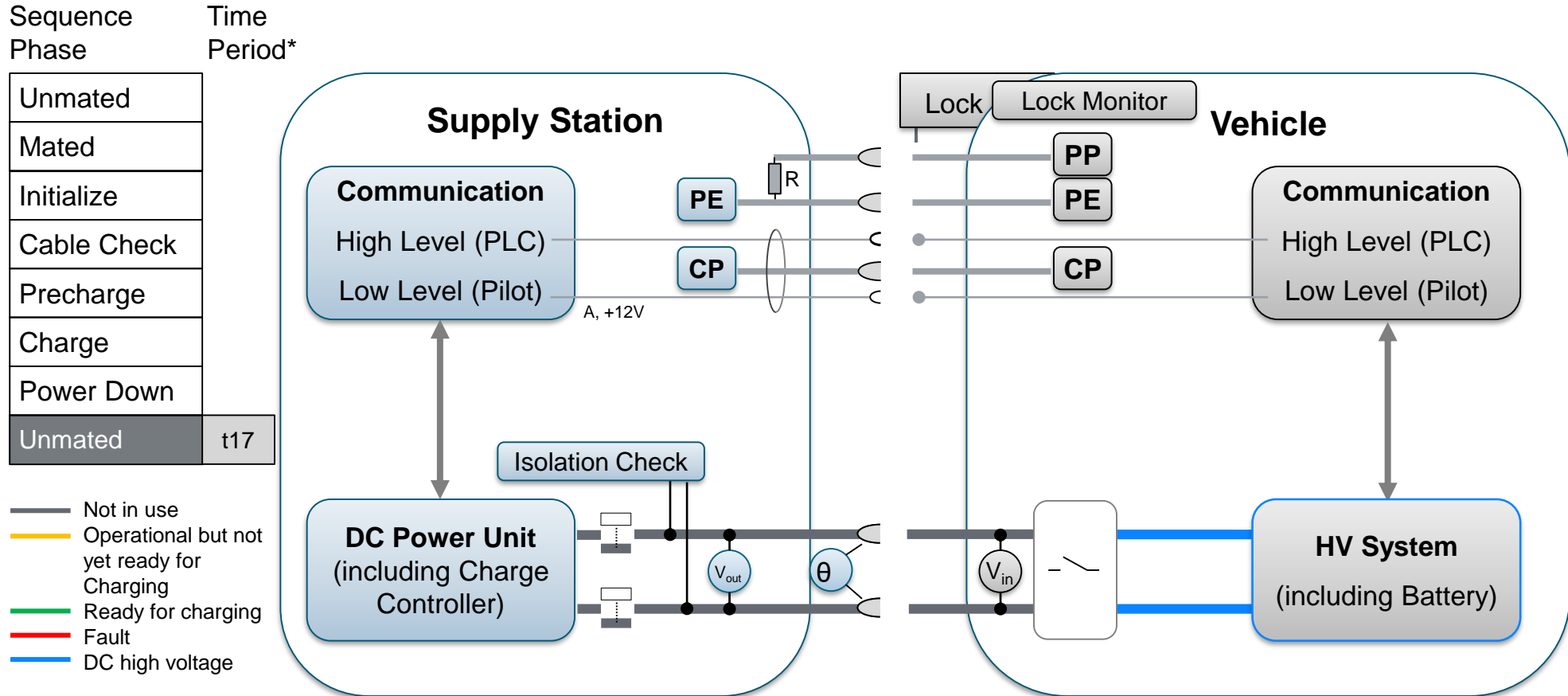

- EV and Supply unmated. Supply disables d.c. output. Lock is disabled. PLC is terminated.
- Disconnecting of vehicle connector changes CP state from B to A.

Agenda

1 Introduction

2 Illustration of Supply Sequence

3 Illustration of Pulse Width Modulation

4 Illustration of SLAC Sequence

5 Illustration of High Level Communication

6 Potential failures within charging sequence (DINSpec 70121 implemented)

7 Safety Concept for Potential Failures within Supply Sequence

8 Additional key points for EVSE's

9 Relevant Standards

Illustration of Pulse Width Modulation

The Pulse Width Modulation (PWM) is the utility for low level communication between EV and EVSE.

The PWM signal is applied to the circuit of control pilot and PE. The standard IEC 61851-1 is defining the meaning of the applicable duty cycle values. Three kind of information can be transmitted:

- Low duty cycle about 3 - 7% = digital communication required
- High duty cycles define the maximum current available
- Invalid duty cycles mean “charging not possible”

The PWM signal is not specific for a.c. or d.c. charging. A.C. charging may use a duty cycle of 5%, which can be found in reality. Also, d.c. charging may use (in theory) a duty cycle of 8% or higher – which would not be compliant with the CCS.

Please note that the duty cycle is controlled by the EVSE, whereas the voltage of the signal is controlled by the EV.

Introduction

- The following slides provide an overview of the states and sequences of the Pulse Width Modulation. It contains
 - a description of the signal,
 - for each state the appropriate function and
 - for each sequence the identified and highlighted active electric components.

Illustration of Pulse Width Modulation

Low Level Communication via Control Pilot for AC/ DC

Hardware based communication channel

Amplitude
And Pulse
Width
Modulated
Oscillator
(PWM)

- Basic frequency 1 kHz
- Duty cycle 3% to 96%
- Amplitude -12 V to +3/ 6/ 9/ 12 V

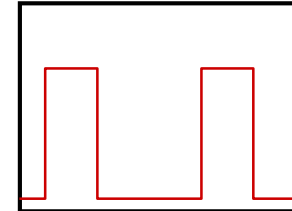

Examples:

30% → 18 A

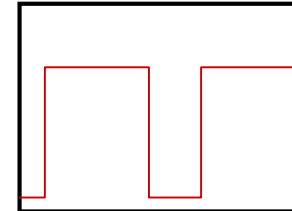

60% → 36 A

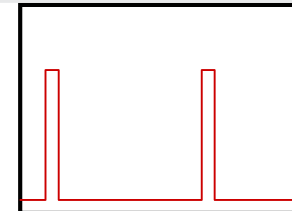

3-7% →
digital communication
required

➤ PWM is a low level communication signal applied to the hardware based pilot circuit.

Illustration of Pulse Width Modulation



Control Pilot System Functions ¹⁾

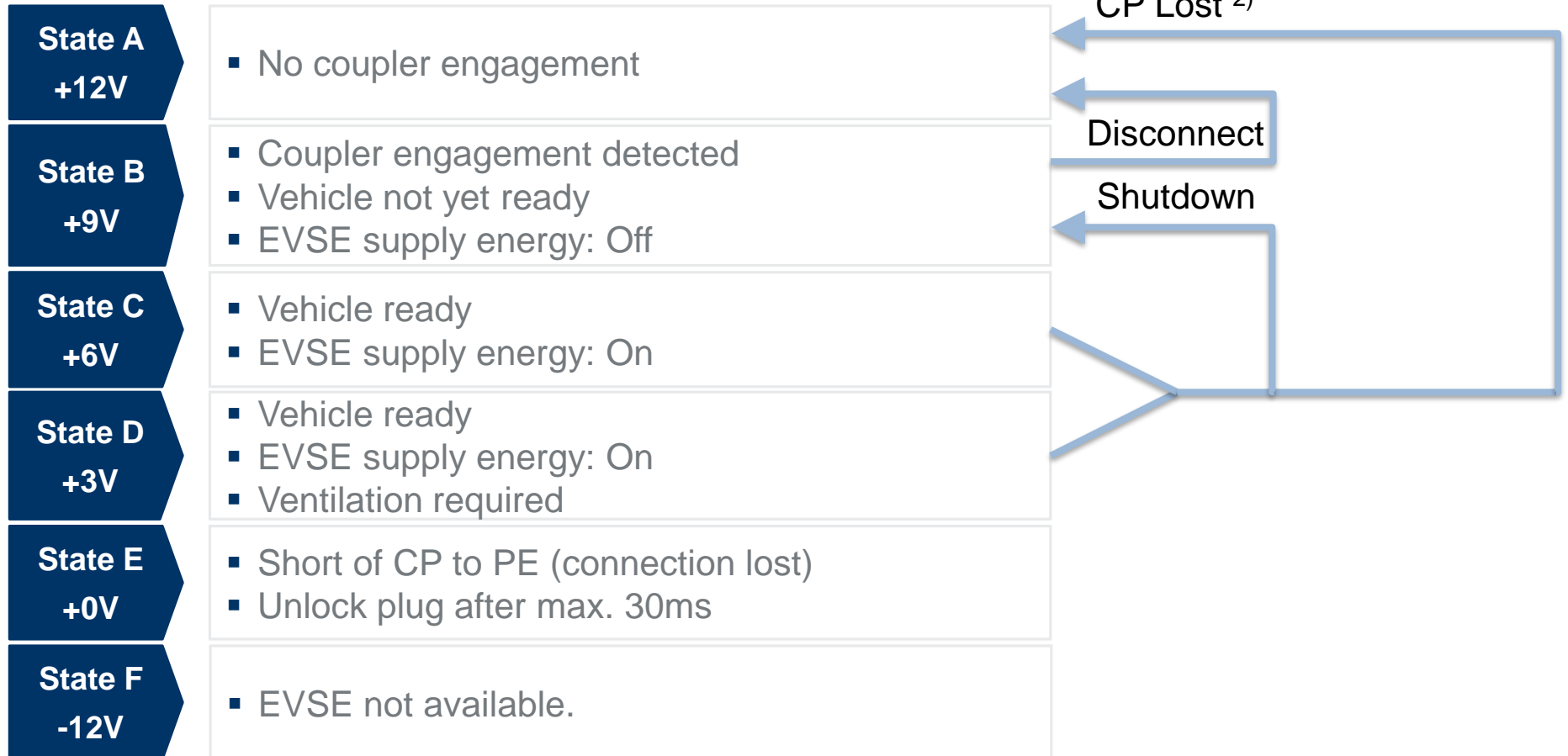

➤ States of low level communication.

¹⁾ IEC 61851-1

²⁾ CCS demands at CP lost an emergency shutdown from EVSE site.

Illustration of Pulse Width Modulation

Unmated

Glossar:

Supply
Infrastructure power supply

Vehicle
Electric Vehicle

PLC
Power Line Communication

CP
Control Pilot

PE
Protective Earth

$\text{---} / \text{---}$
Physical / functional connection

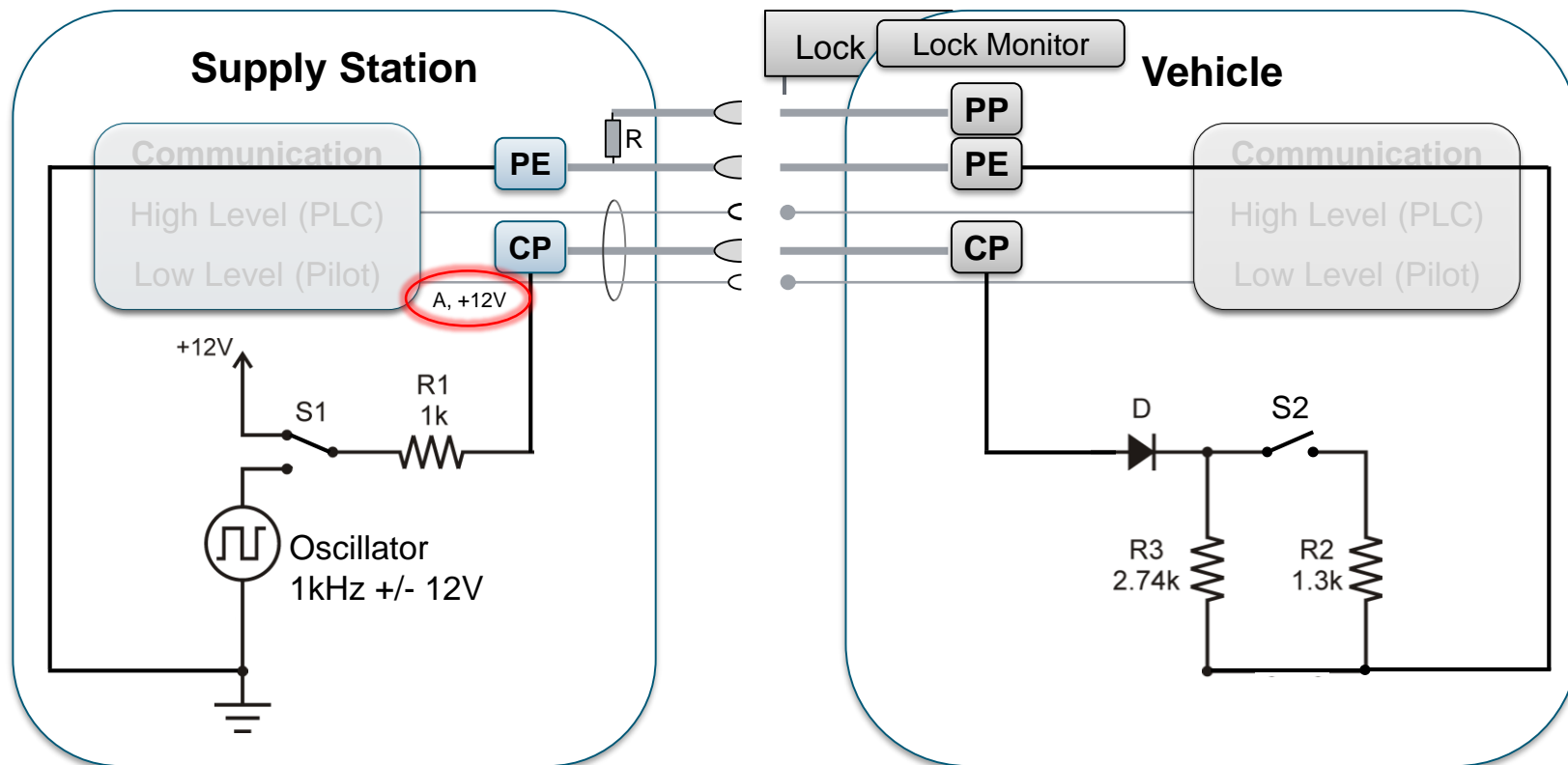

➤ Schematic shows only the relevant physical and functional elements for illustration. Supply Station and Vehicle are disconnected. The initial 12V pilot voltage is measured by the Supply Station at R1.

Illustration of Pulse Width Modulation

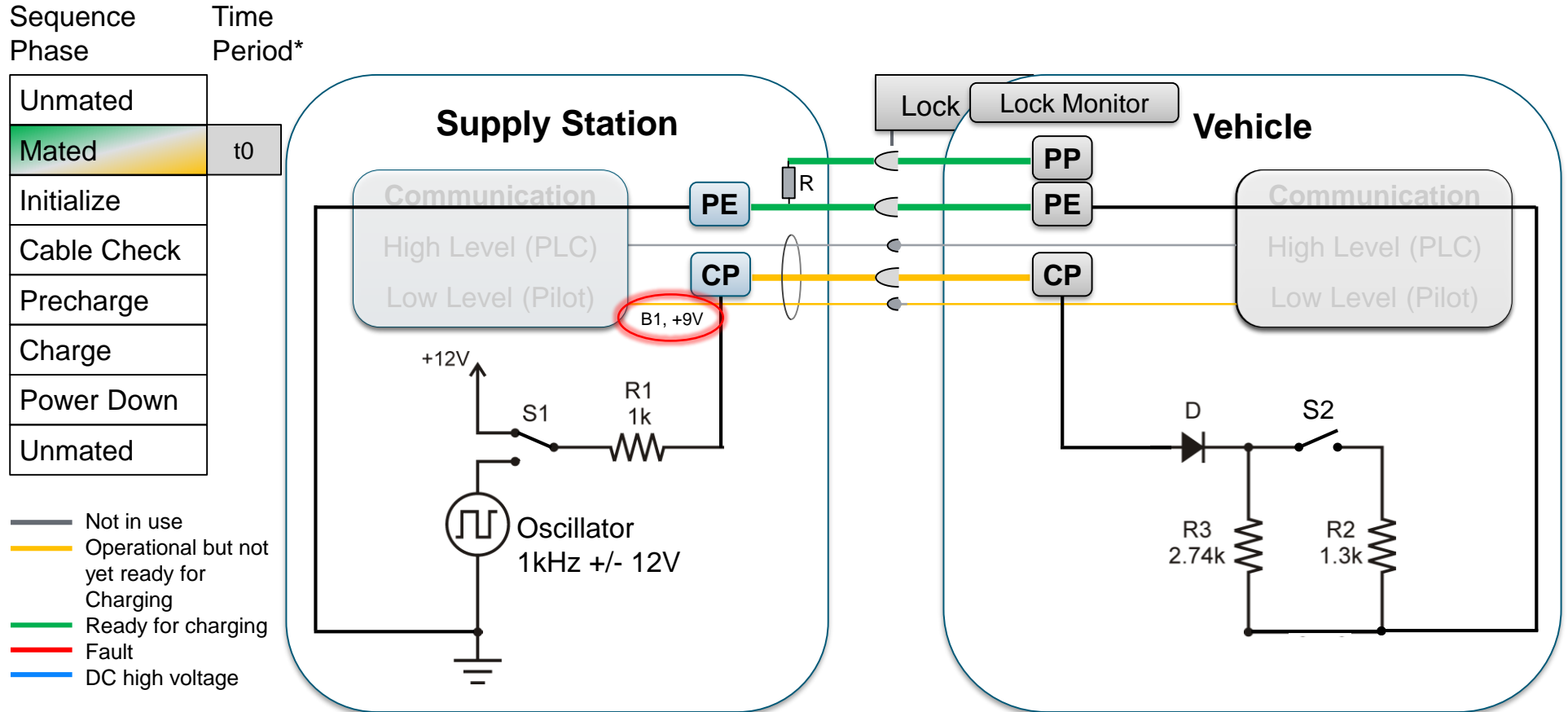

* According to IEC 61851-23

➤ CP enters state B1 instantly with mating. This condition is detected by the 9V signal measured at R1. Vehicle is immobilized (PP).

Illustration of Pulse Width Modulation

Sequence Phase Time Period*

Unmated
Mated
Initialize
Cable Check
Precharge
Charge
Power Down
Unmated

t1-2

- Not in use
- Operational but not yet ready for Charging
- Ready for charging
- Fault
- DC high voltage

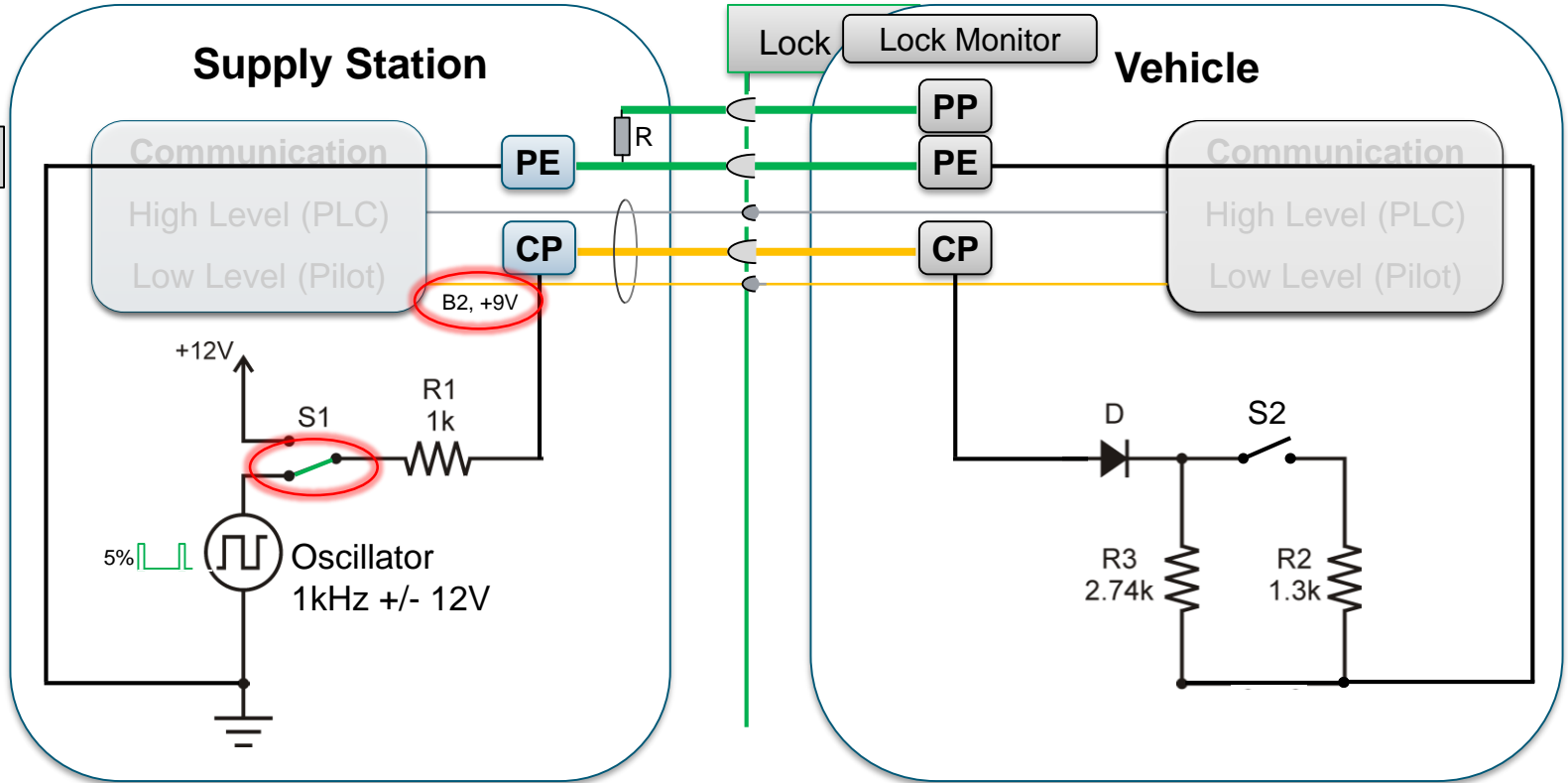

* According to IEC 61851-23

➤ The Supply Station is sending a request (5% duty cycle) to establish High Level Communication via PLC.

Illustration of Pulse Width Modulation

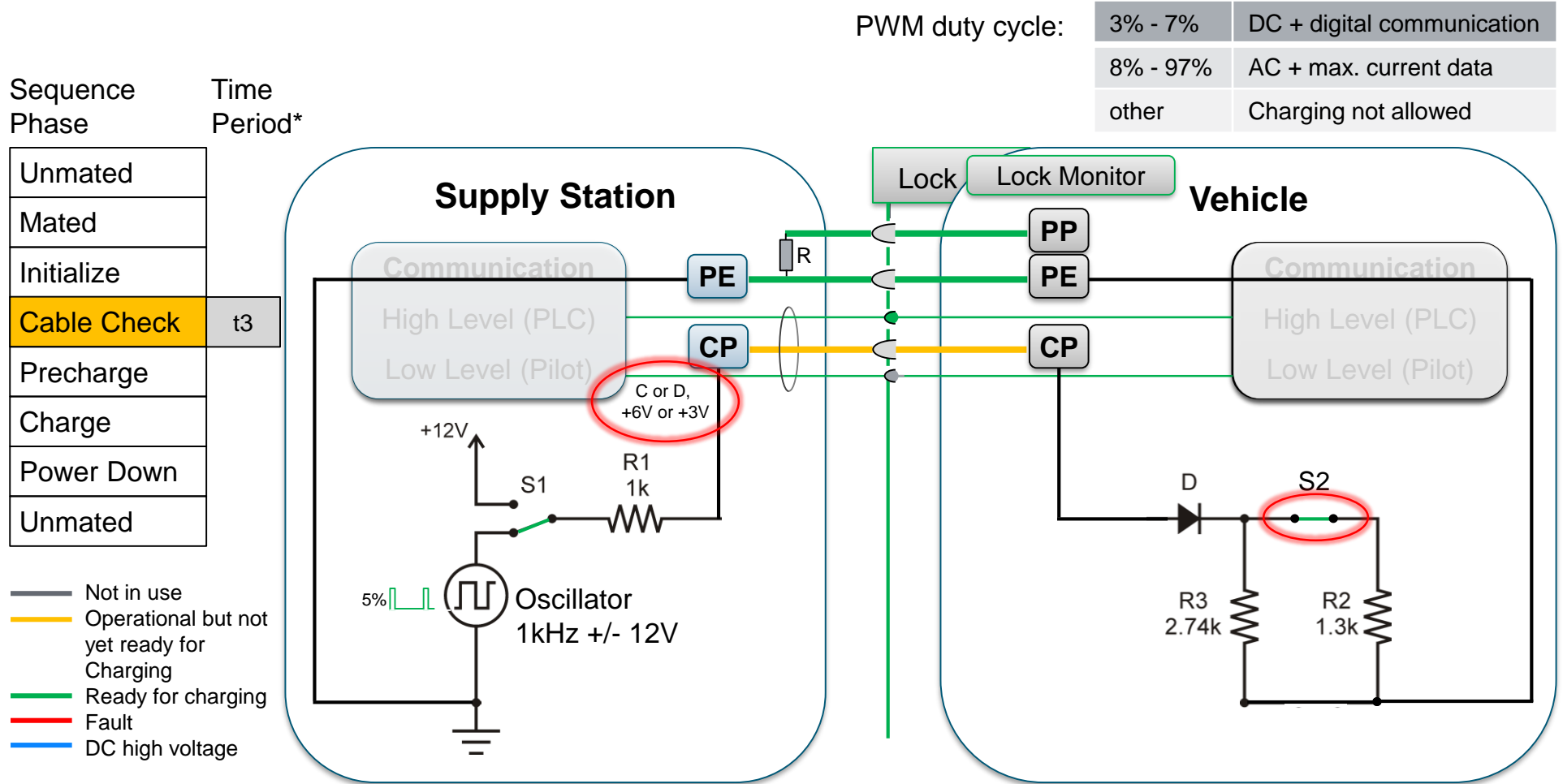

* According to IEC 61851-23

➤ After successful initialization of PLC communication the vehicle indicates readiness to receive energy by closing S2.

Illustration of Pulse Width Modulation

PWM duty cycle:	3% - 7%	DC + digital communication
	8% - 97%	AC + max. current data
	other	Charging not allowed

Sequence Phase Time Period*

Unmated
Mated
Initialize
Cable Check
Precharge
Charge
Power Down
Unmated

t10

- Not in use
- Operational but not yet ready for Charging
- Ready for charging
- Fault
- DC high voltage

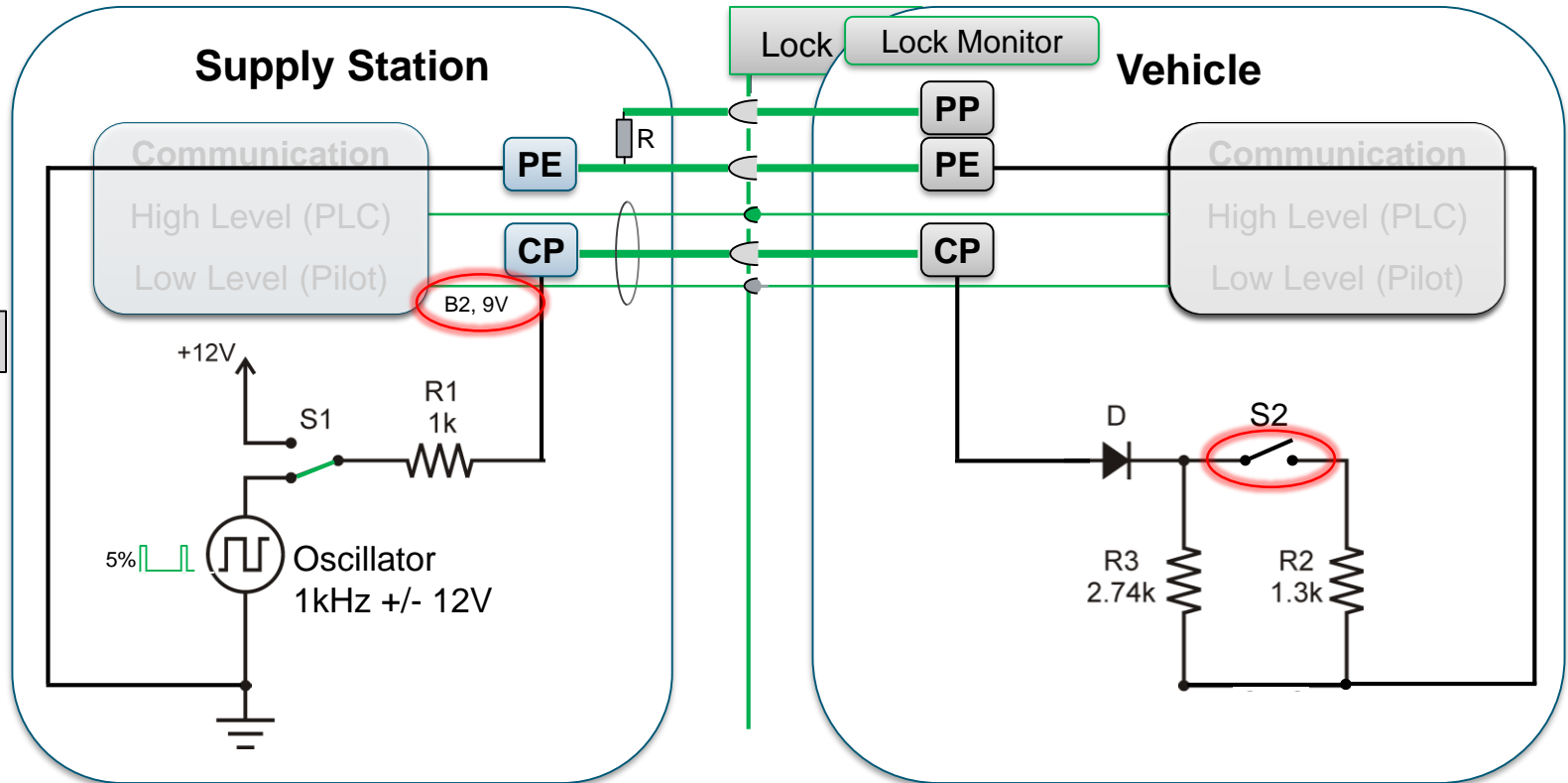

* According to IEC 61851-23

- During a non normal energy transfer, the vehicle can shut down the charging process via opening S2 (pilot function). The state changes from C/D to B2.

Illustration of Pulse Width Modulation



Lesson learned: Rising Edge Detection

Problems

- The ideal curve becomes more difficult to detect when applying noise and additional capacities
- Random micro-inversions of the direction lead to misinterpretation

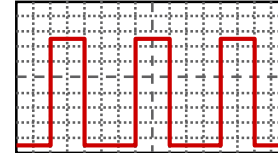

Ideal Curve

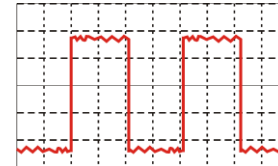

Plus Noise

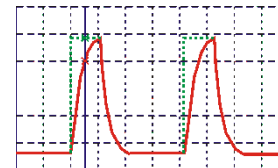

Plus Capacities

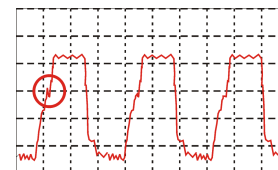

Plus Capacities & Noise

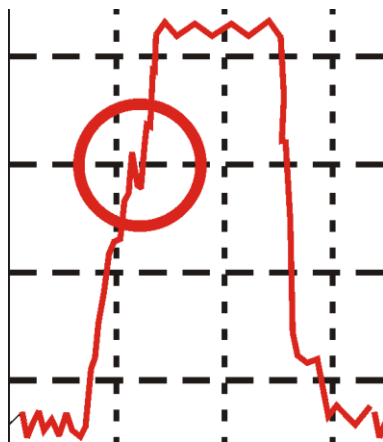

➤ Previous field tests have discovered problems in the implementation of the IEC 61851-1. Charging stations require a robust and reliable implementation strategy.

Illustration of Pulse Width Modulation



Lesson learned: Detection Thresholds

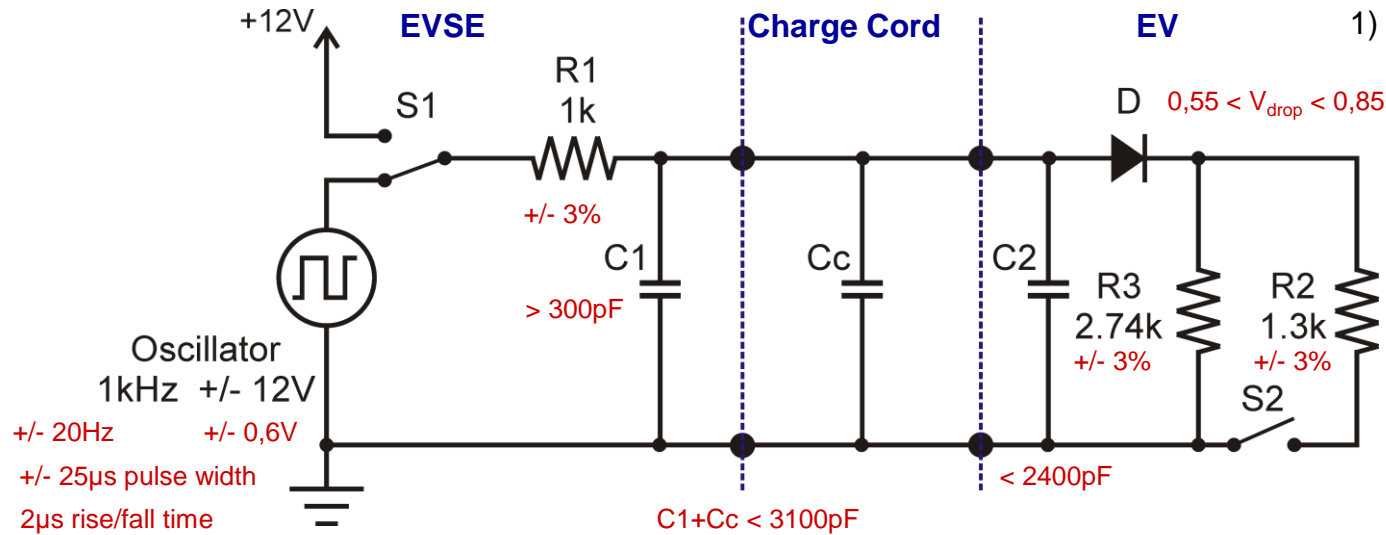

Problems

State	U_{+nom}
B	9 V
C	6 V
D	3 V



Pilot voltage ranges from ± 1 V to given U_{+nom} in addition to Noise ($\pm 0,5$ V). See also IEC TS 62763.

- Current detection thresholds are checked for robustness and reliability

- Definition of thresholds should be necessary to ensure the interoperability. Amended Annex A includes the necessary thresholds definitions. The pilot is robust and interoperable.

¹⁾ Example circuit, see also IEC 61851-1, Annex A

Agenda

1 Introduction

2 Illustration of Supply Sequence

3 Illustration of Pulse Width Modulation

4 Illustration of SLAC Sequence

5 Illustration of High Level Communication

6 Potential failures within charging sequence (DINSpec 70121 implemented)

7 Safety Concept for Potential Failures within Supply Sequence

8 Additional key points for EVSE's

9 Relevant Standards

Illustration of SLAC I

The Signal Level Attenuation Characterization (SLAC) is a protocol to ensure EV and EVSE are physically connected to each other. SLAC as part of layer 2 (data link) is defined in HomePlug Green PHY v1.1.1 specification.

SLAC is a protocol to measure the attenuation between two Power Line Communication (PLC) modules. If there are several EV's that are connected to charging stations nearby, there can occur crosstalk in between.

SLAC requests shall be responded by an EVSE only, if the EVSE is connected to an EV (state B) and the PLC module of the EVSE is not already linked to another PLC module (unmatched state).

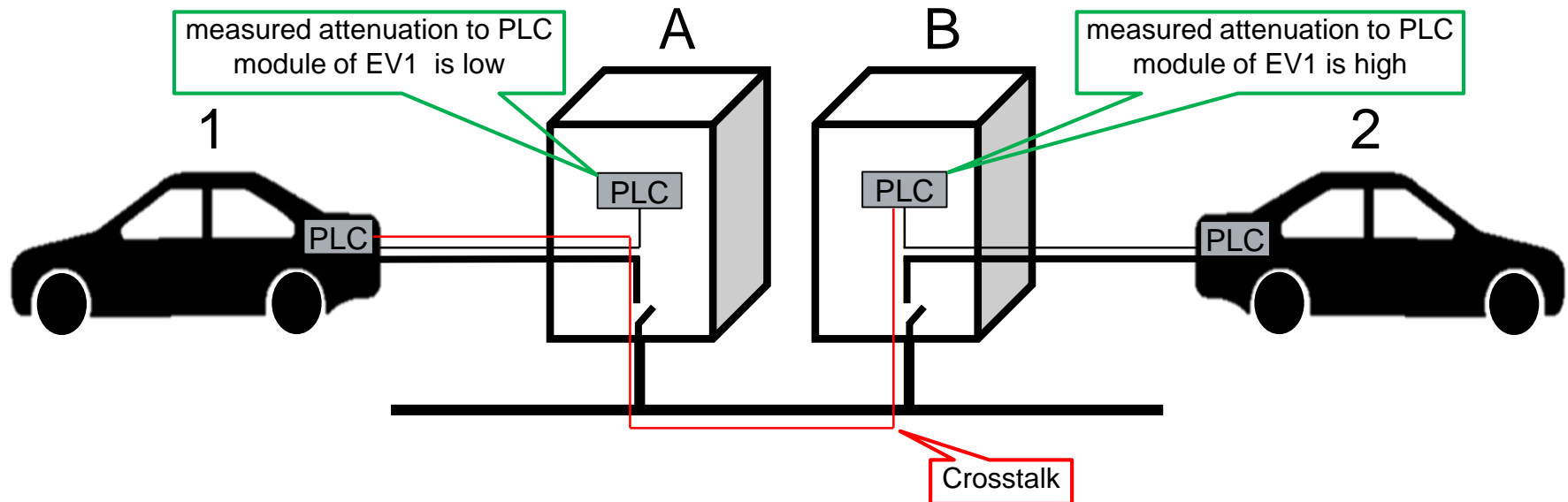

- To ensure communication only between physically connected EV and EVSE, SLAC procedure is performed. PLC modules which show the lowest attenuation to each other are physically connected.

Illustration of SLAC II

SLAC sequence

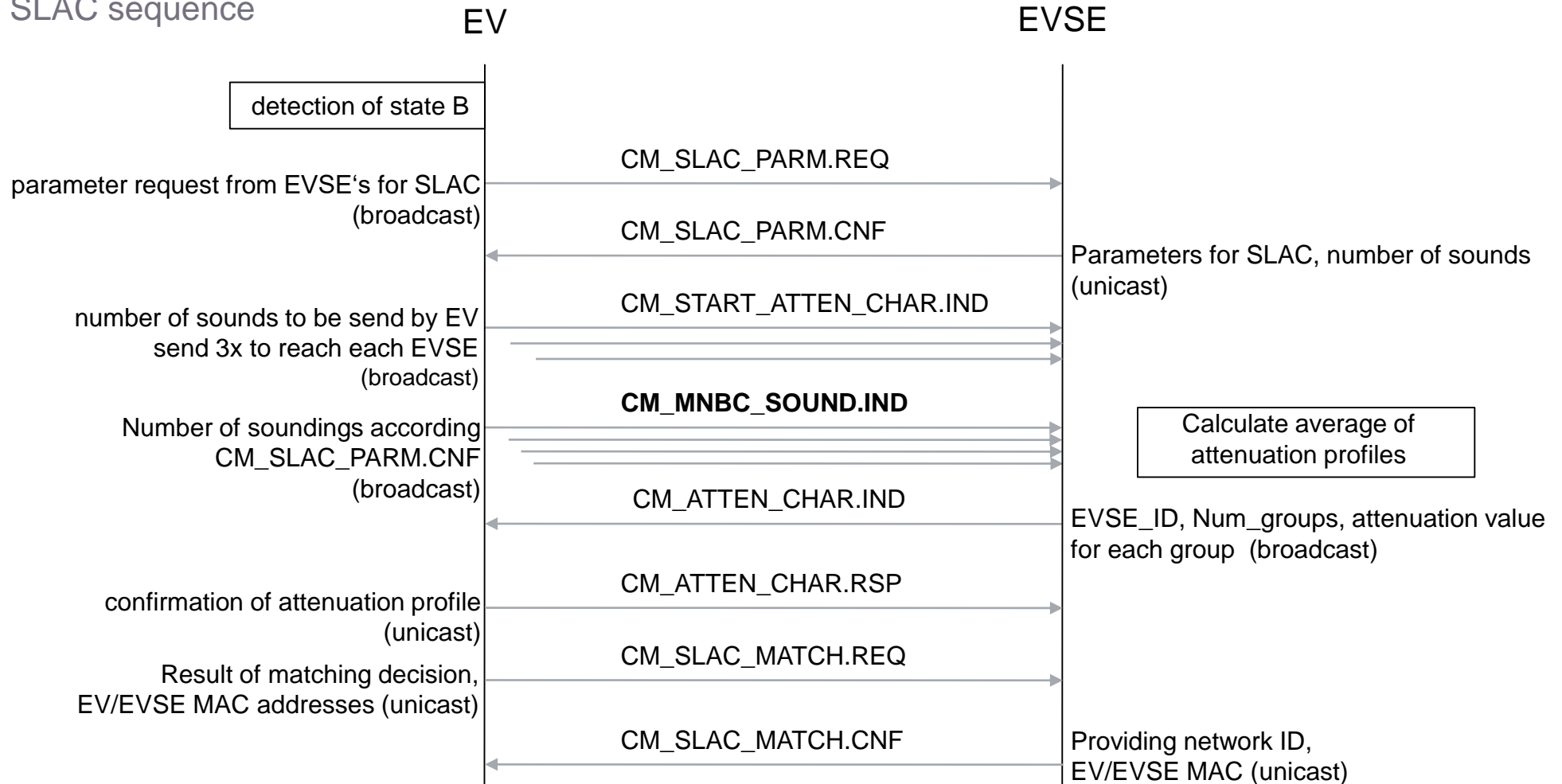

- After succesful SLAC procedure, PLC module of EVSE and the physically connected PLC module of the EV set up a network.

Agenda

1 Introduction

2 Illustration of Supply Sequence

3 Illustration of Pulse Width Modulation

4 Illustration of SLAC Sequence

5 Illustration of High Level Communication

6 Potential failures within charging sequence (DINSpec 70121 implemented)

7 Safety Concept for Potential Failures within Supply Sequence

8 Additional key points for EVSE's

9 Relevant Standards

Illustration of High Level Communication

The illustration of High Level Communication is a simplified systematic description of the communication between EV and DC Supply from start up after the plug-in of the charging cable.

The High Level Communication in DC charging takes place via power line communication (PLC) and is used for exchange of charging parameters e.g. voltage and current as well as information's like state of charge, remaining charging time, next maintenance. There is also the possibility to enable and operate a payment system via high level communication.

Introduction

- Based on the **Open System Interconnection-Layer-Model (OSI)** the different stages of the communication between EV and DC supply have been investigated.
- The following overview describes the stages of the High Level Communication. It contains
 - For each sequence the identified OSI Layers, beginning with the physical connection and proceeding step by step to the control application.
 - Clarification what happens and which preconditions must be given so that EV and DC Supply can communicate with each other.
 - A description of point to point relationship between PLC modules on EV and DC Supply.

Illustration of High Level Communication

OSI-Layer-Model

Pre-condition

- For communication the DC charging system requires one dedicated Power Line Controller node on EV and DC Supply side

OSI-Layer Model

- The Communication is based on the OSI-Layer-Model containing 7 layers.
- Each of the 7 layers provides a dedicated task for the integrated communication process.
- As a result each layer adds a data package to the message container.
- Communication can be established if sender and receiver are synchronized on the message container format.

Example

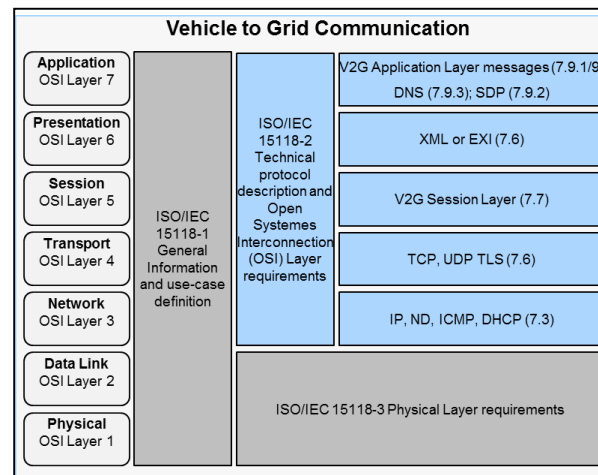

Illustration of High Level Communication

Abbreviated terms

For the purpose of the document „Illustration of High Level Communication“, the following abbreviations apply:

CP	Control Pilot
DC	Direct Current
DHCP	Dynamic Host Control Protocol
DNS	Domain Name Service
EXI	Efficient XML Interchange
ICMP	Internet Control Message Protocol
IP	Internet Protocol
ND	Neighbor Discovery
OSI	Open System Interconnection-Layer-Model
PE	Protective Earth
PHY	Physical Layer
PLC	Power Line Communication
PWM	Pulse Wide Modulation
SDP	SECC Discovery Protocol
SLAC	Signal Level Attenuation Characterization
TCP	Transmission System Protocol
TLS	Transport Layer Security
UDP	User Datagram Protocol
V2G	Vehicle-to-Grid Communication
XML	Extensible Markup Language

Illustration of High Level Communication

OSI-Layer-Model and Standards

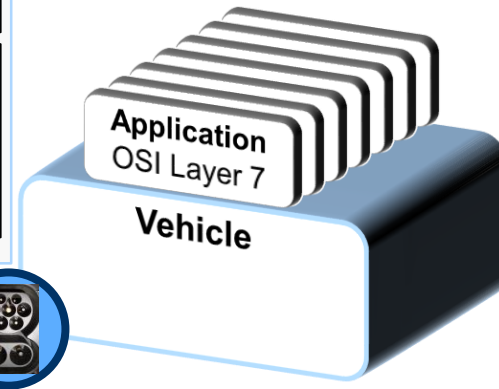
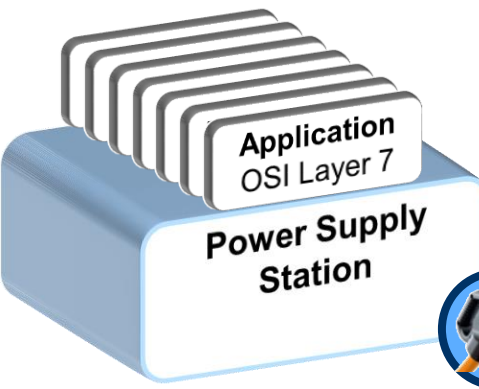
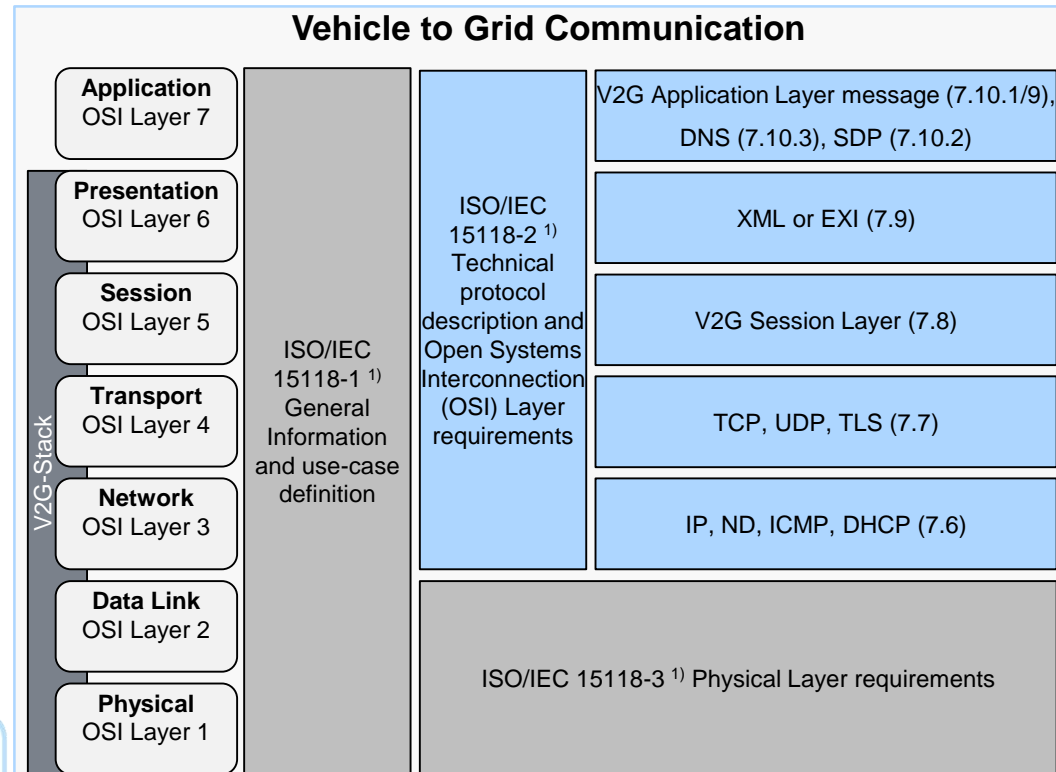

➤ The Data Link is performed via Power Line Communication technology Home Plug Green PHY (IEEE1901).

¹⁾ In conjunction with ISO/IEC 15118 please note also DIN SPEC 70121.

Illustration of High Level Communication

OSI-Layer 1

Precondition:

- PE & Control Pilot connected
- PWM 5% Status „B“
- On both sides: compatible Home Plug Green PHY modems

Task:

- Establish physical link on the PE-CP wires to the opposite side.

Result:

- PLC module ready for communication with a established frequency band of 1,8 MHz to 30 MHz

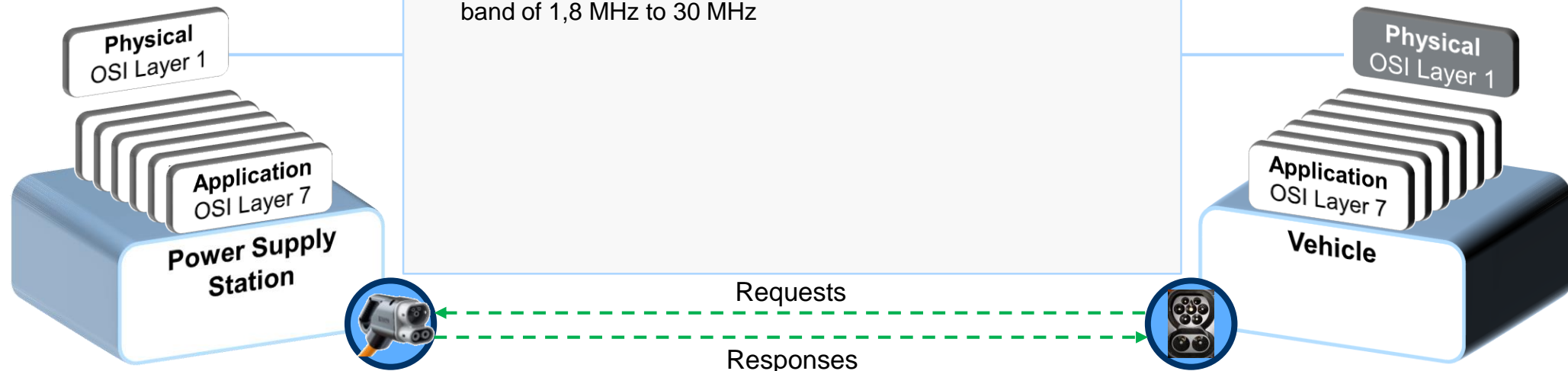

- Layer ensures the activation of physical connections (mechanical, electric, functional interfaces) to provide bidirectional data transfer between EV and DC Supply.
- Standard Ref: ISO/IEC 15118-3 ¹⁾ Clause 8 and 9

¹⁾ In conjunction with ISO/IEC 15118 please note also DIN SPEC 70121.

Illustration of High Level Communication

OSI-Layer 2

Precondition:

- Successful established OSI Layer 1

Task:

- Configuration of PLC nodes
- Determination of the connected Power Supply PLC module with measurement of signal strength by using the Signal Level Attenuation Characterization (SLAC) process
- Confirm the „Association process“
- Set-up logical network

Result:

- Established Link to higher layer entities

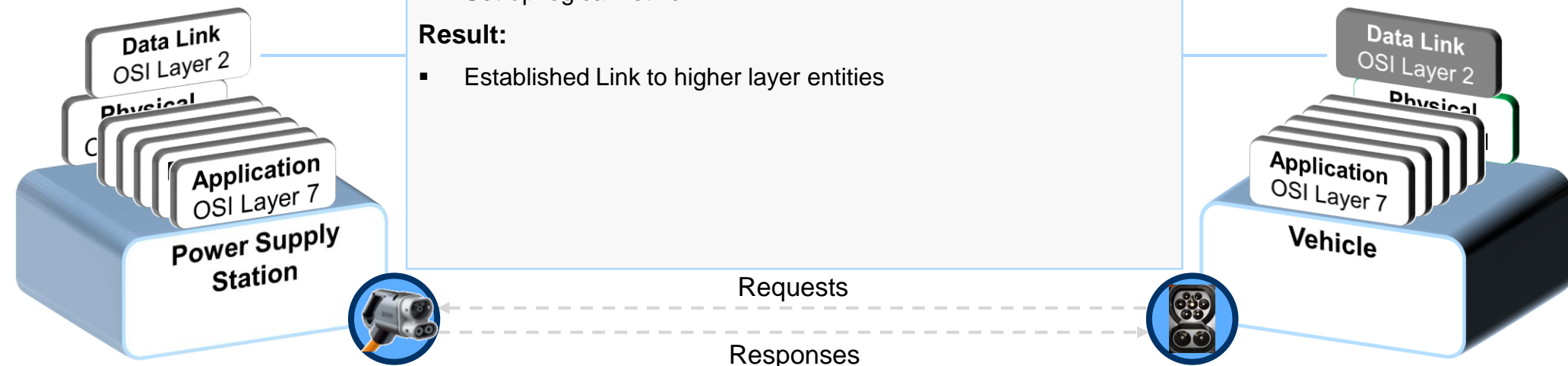

- Layer Link guarantees a error-free data transfer of data frames from one node to another over the physical layer.
- Standard Ref: ISO/IEC 15118-2 7.5, ISO/IEC 15118-3 Clause 12 ¹⁾

¹⁾ In conjunction with ISO/IEC 15118 please note also DIN SPEC 70121.

Illustration of High Level Communication

OSI-Layer 3

Precondition:

- Successful established OSI Layer 2

Task:

- Implement the IPv6 Internet Protocol Standard
- Entities implement the „must“ requirements of applicable limitations, request for comments (RFCs) and protocol parameter settings
- Ensure unique addresses by using neighbor broadcast protocol
- Implementation of ICMPv6 to send error messages

Result:

- All actors retrieves valid IP addresses



- Layer controls the routing and switching of connections deciding which physical path the data should take.
- Standard Ref: ISO/IEC 15118-2 7.6 ¹⁾

¹⁾ In conjunction with ISO/IEC 15118 please note also DIN SPEC 70121.

Illustration of High Level Communication

OSI-Layer 4

Precondition:

- Successful established OSI Layer 3

Task:

- All entities implement Transmission Control Protocol (TCP)
- All entities implement User Datagram Protocol (UDP)
- All entities implement optional Transport Layer Security (TLS) ²⁾

Result:

- Establishing reliable (TCP), fast (UDP) and safe (TLS) data connection between entities
- TCP provides flow control and congestion control and provides algorithm to handle congestion and influence flow control

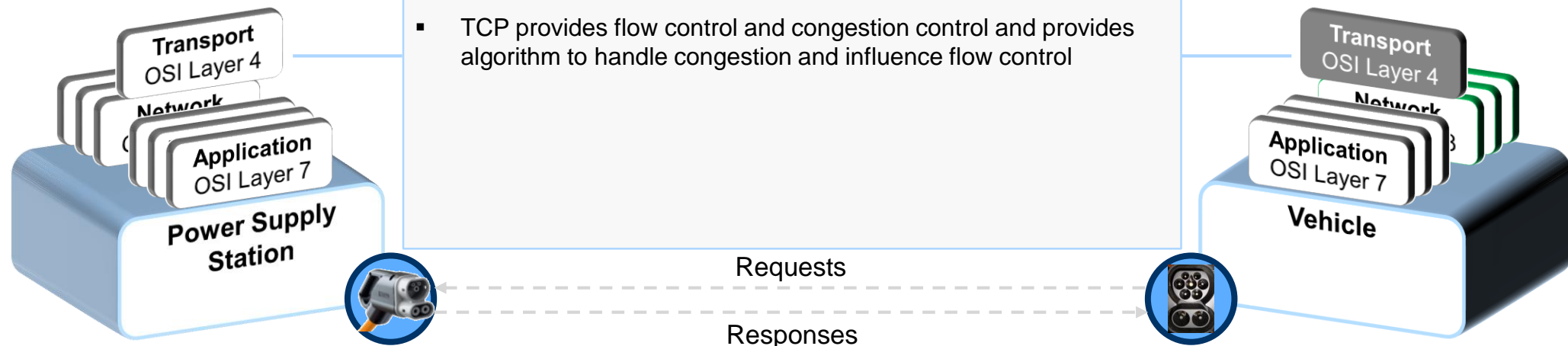

- Layer ensures the error-free flow and congestion of the data stream with no losses or duplications.
- Standard Ref: ISO/IEC 15118-2 7.7 ¹⁾

¹⁾ In conjunction with ISO/IEC 15118 please note also DIN SPEC 70121.

²⁾ Not applicable in DIN SPEC 70121

Illustration of High Level Communication

OSI-Layer 5

Precondition:

- Successful established OSI Layer 4

Task:

- Entities implement V2G Transfer Protocol (V2GTP)
- Establishes, manages and terminates connections between the entities by using IP addresses and port numbers

Result:

- Established and identified connections for bidirectional data exchange

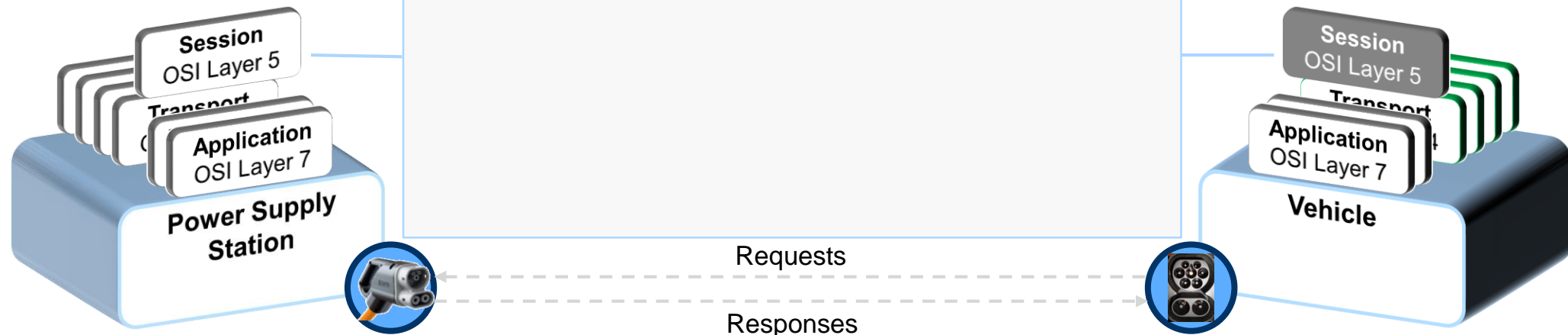

- Layer establishes and identifies a connection for bidirectional data exchange.
- Standard Ref: ISO/IEC 15118-2 7.8 ¹⁾

¹⁾ In conjunction with ISO/IEC 15118 please note also DIN SPEC 70121.

Illustration of High Level Communication

OSI-Layer 6

Precondition:

- Successful established OSI Layer 5
- All entities have to use encoding format according to definition in W3C EXI 1.0

Task:

- Coding and decoding from application to network format EXI
- Establish between EV and DC Supply an appropriate application layer protocol including its version via handshake (sending a „supportedAppProtocolReq“ and responding a „supportedAppProtocolRes“)
- Implement a message structure with a message header (contains Session ID, Notification, Signature) and message body (represents the abstract message information)

Result:

- Enables simplified validity evaluation of exchanged messages
- Compatibility of data exchange between all entities

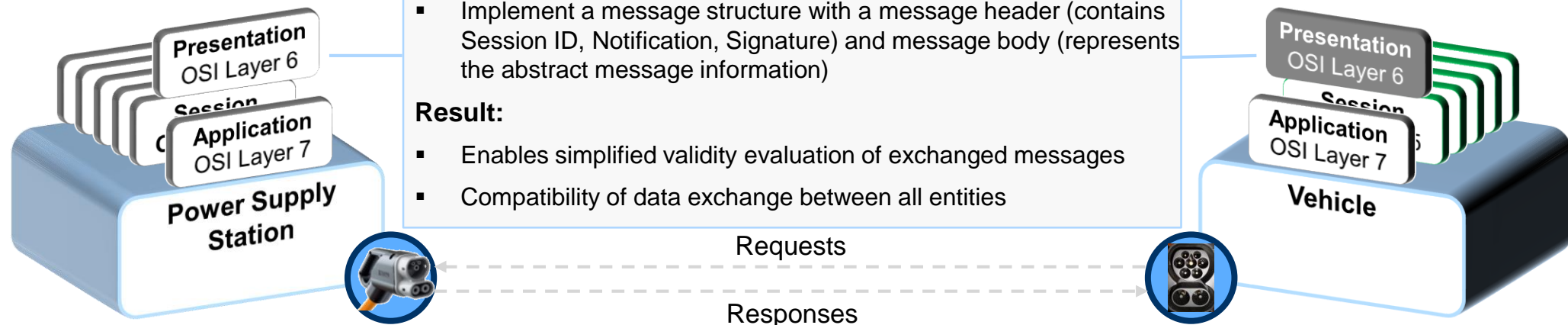

- Layer transforms system dependent data into an independent shape and enables thereby the syntactically correct data exchange between different systems. It can be viewed as the translator of the system.
- Standard Ref: ISO/IEC 15118-2 7.9 ¹⁾

¹⁾ In conjunction with ISO/IEC 15118 please note also DIN SPEC 70121.

Illustration of High Level Communication

OSI-Layer 7

Precondition:

- Successful established OSI Layer 6

Task:

- Establish charging process (i.e. identification, precharge, charge, security check...)

Result:

- Representing the client-server based message and the required communication protocol

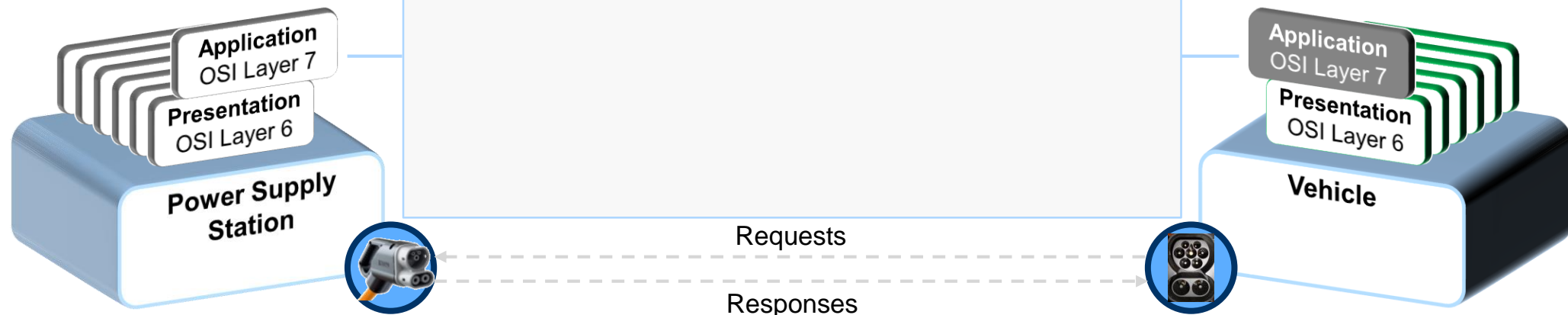

- Layer is initializing and configuring the charge process of an EV.
- Standard Ref: ISO/IEC 15118-2 7.10 ¹⁾

¹⁾ In conjunction with ISO/IEC 15118 please note also DIN SPEC 70121.

Illustration of High Level Communication

OSI-Layer-Model: Package Assembling

(Data + Header = Message)

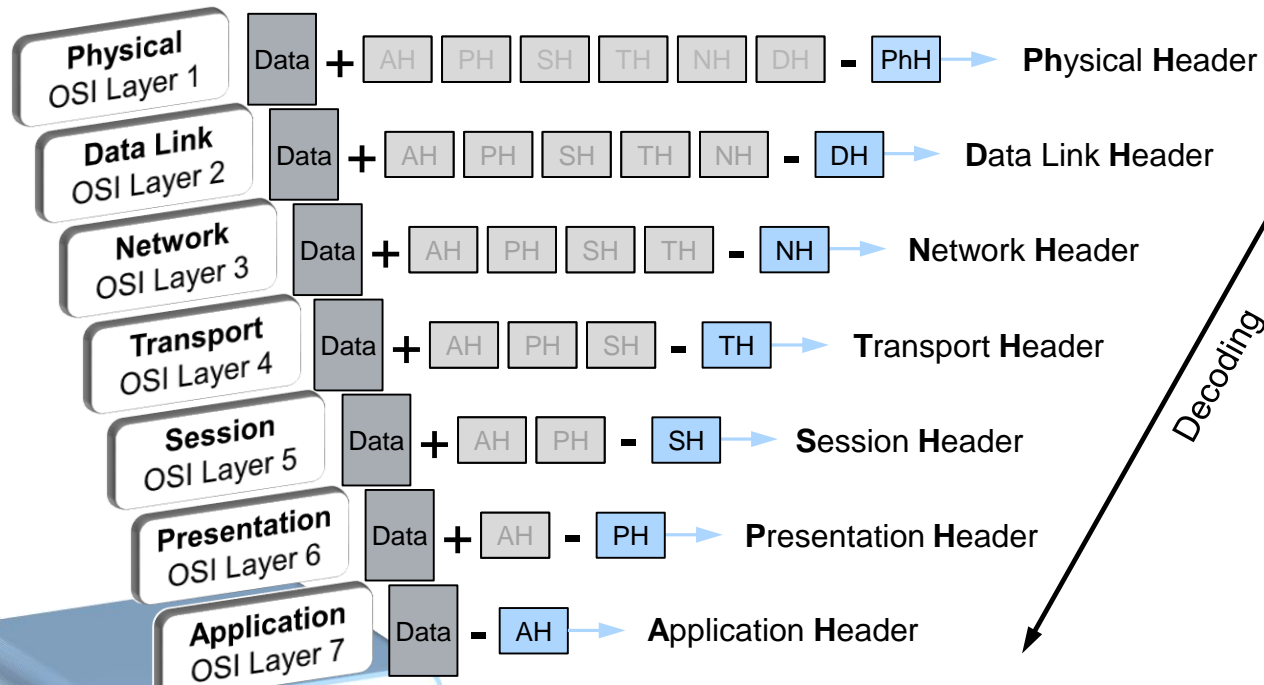

Decoding

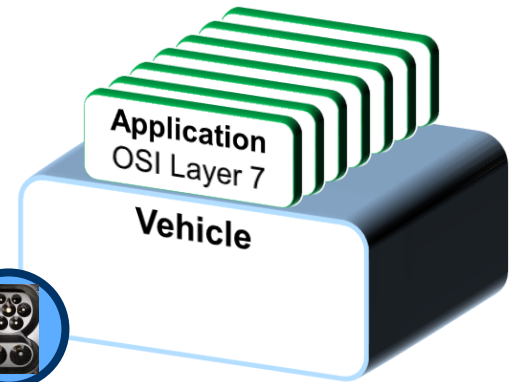

Requests

Responses

- Each Message contains the data packet and specific headers.

Illustration of High Level Communication

OSI-Layer-Model: Package Assembling

(Data + Header = Message)

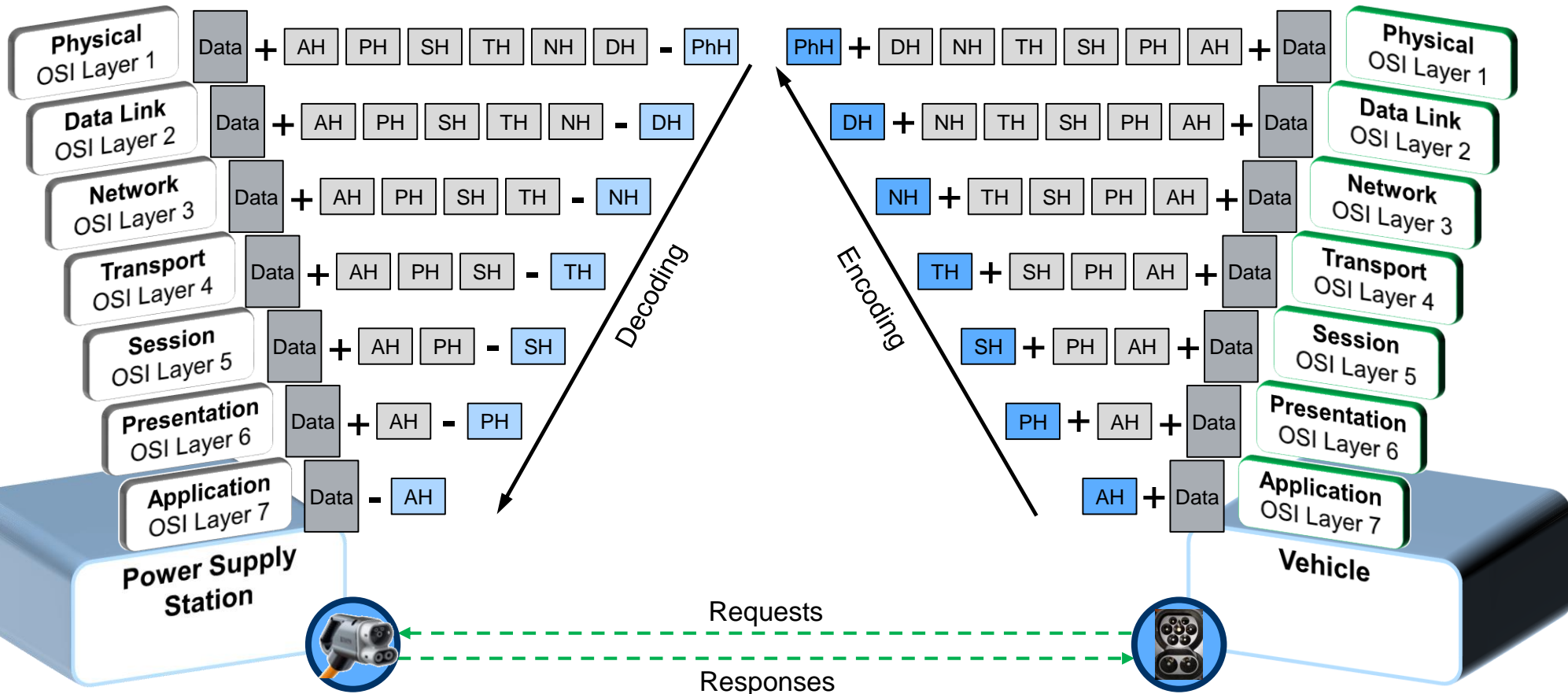

- During the communication process each Layer is encoding (addition) or decoding (subtraction) the layer specific header.

Illustration of High Level Communication

OSI-Layer-Model: Timeouts

ISO/IEC 15118-2

Table 103 — EVCC EVCC and SECC Message sequence and session timing parameter values

Name	MessageType	Value [s]
V2G_EVCC_Msg_Timeout(MessageType)	SupportedAppProtocol	2
	SessionSetup	2
	ServiceDiscovery	2
	ServicePaymentSelection	2
	PaymentDetails	5
	ChargeParameterDiscovery	2
	ChargingStatus	2
	MeteringReceipt	2
	PowerDelivery	2
	CableCheck	25
	PreCharge	1
	CurrentDemand	0,25
	WeldingDetection	1
	SessionStop	2
	CertificateInstall	5
	CertificateUpdate	5

Name	MessageType	Value [s]
V2G_SECC_Msg_Performance_Time(MessageType)	SupportedAppProtocol	1,5
	SessionSetup	1,5
	ServiceDiscovery	1,5
	ServicePaymentSelection	1,5
	PaymentDetails	4,5
	ChargeParameterDiscovery	1,5
	ChargingStatus	1,5
	MeteringReceipt	1,5
	PowerDelivery	1,5
	CableCheck	20
	PreCharge	0,1
	CurrentDemand	0,025
	WeldingDetection	0,1
	SessionStop	1,5
	CertificateInstall	4,5
	CertificateUpdate	4,5
V2G_EVCC_Sequence_Performance_Time	(all messages)	40
V2G_SECC_Sequence_Timeout	(all messages)	60



- Timeouts are defined in ISO/ IEC 15118 ¹⁾, Part 2 and 3.
- The above table is an illustration of how timeouts are specified.

¹⁾ In conjunction with ISO/IEC 15118 please note also DIN SPEC 70121.

Illustration of High Level Communication

OSI-Layer-Model Summary

Summary

- Each respective lower layer provides its services to the layer above via defined interfaces.
- Messages (Application Process) has to be passed down through the protocol stack from upper to lower layers. Each Layer adds the specific header.
- After EV has sent message over the lowest (physical medium) layer, the message passes upwards through all the higher layers at the Power Supply until it reaches the application layer. Each Layer subtract the specific header.
- The whole process requires a logical interaction within each layer to complete the High Level Communication.

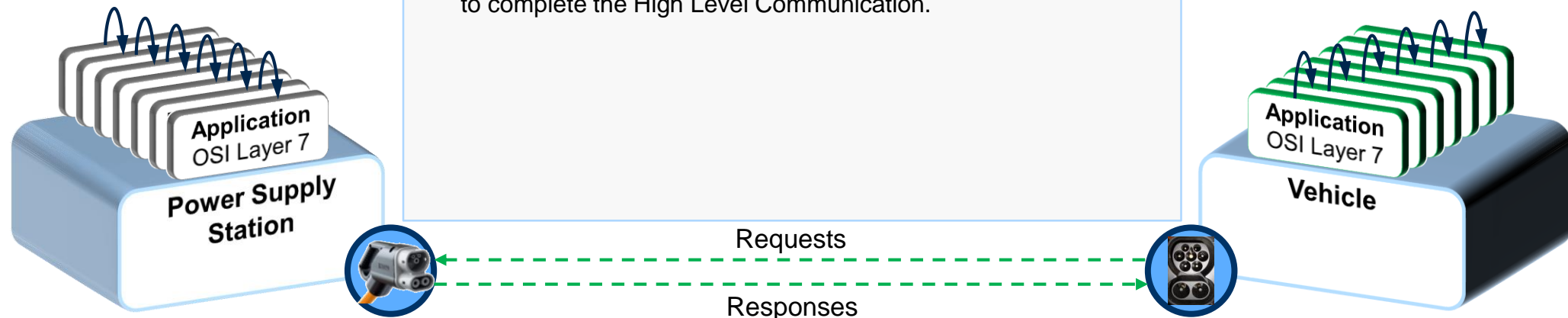

Agenda

1 Introduction

2 Illustration of Supply Sequence

3 Illustration of Pulse Width Modulation

4 Illustration of SLAC Sequence

5 Illustration of High Level Communication

6 Potential failures within charging sequence (DINSpec 70121 implemented)

7 Safety Concept for Potential Failures within Supply Sequence

8 Additional key points for EVSE's

9 Relevant Standards

Failures during SLAC

SLAC does not start I

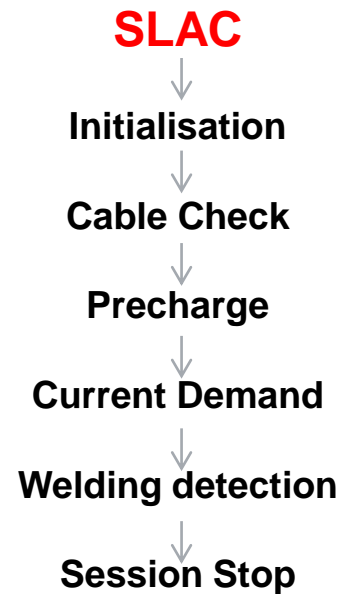

behaviour:

- SLAC does not start after plug-in of connector

analysis:

- PLC chip inside EVSE is not ready for communication (e.g. ongoing reset of PLC module inside EVSE)
- EVSE is not part of the matching process

possible solution(s):

- (CM_Set_Key.req) shall be done by EVSE after every plug-out of the connector (change to state A)

Failures during SLAC

SLAC does not start II

Reset of PLC chip inside the EVSE is done before change of duty cycle to state B. EV will immediately start SLAC at detecting state B.

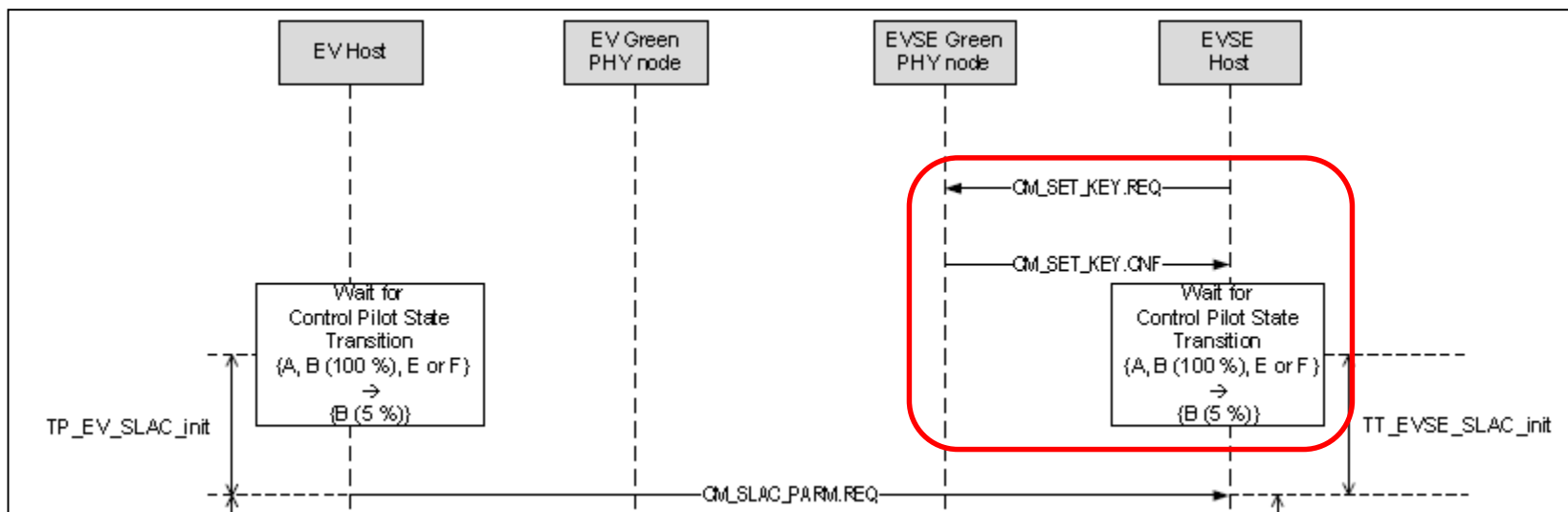

source: DIN SPEC 70121:2014-12, 8.3.4 , Figure 8

Failures during SLAC

Interruption after soundings I

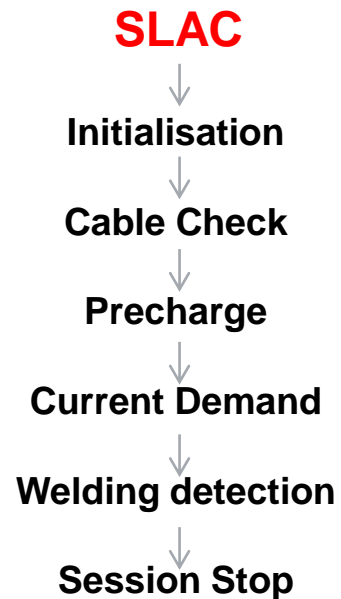

behaviour:

- Sounding-sequence is send several times by EV

analysis:

- EV does not receive V2G-message CM_ATTEN_CHAR.IND by EVSE
- EV receives V2G-message CM_ATTEN_CHAR.IND too late

possible solution(s):

- Adjustments of transmission power of PLC-Chip inside EVSE
- Adjustments for processing inside EVSE

Failures during SLAC

Interruption after soundings II

CM_ATTEN_CHAR.IND has to be send by EVSE, max.700ms after first CM_START_ATTEN_CHAR.IND from EV side is received

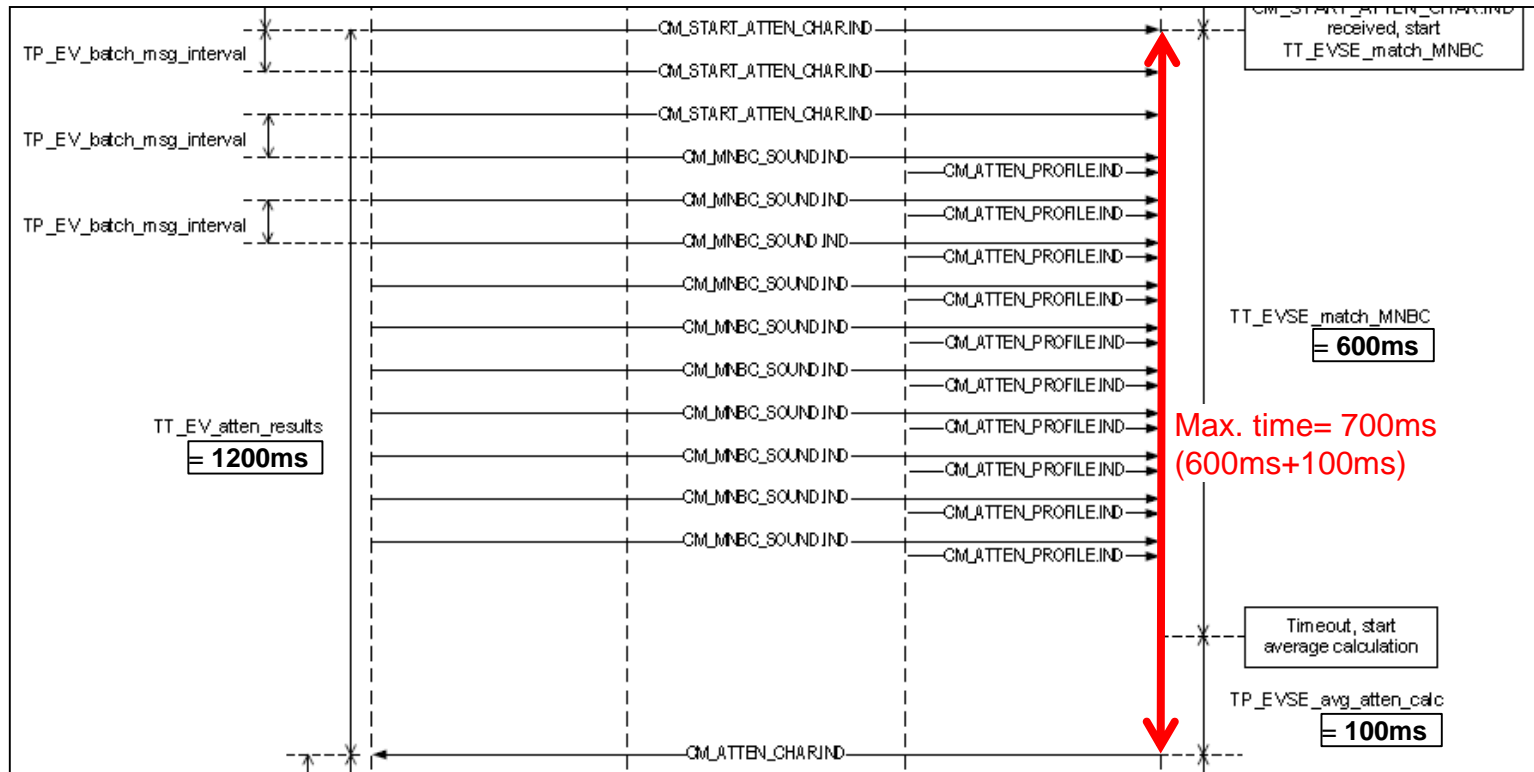

source: DIN SPEC 70121:2014-12, 8.3.4, Figure 8

Failures during SLAC

Interruption after soundings III

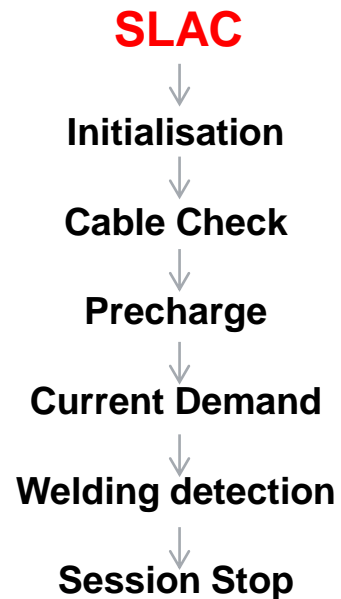

behaviour:

- EV interrupts after message CM_ATTEN_CHAR.IND is send by EVSE

analysis:

- The message CM_ATTEN_CHAR.IND does not include the correct number of „num_groups“

possible solution(s):

- The number of „num_groups“ has to be equal to value, which is send in the same message (0x3A→ 58 num_groups)

Failures during SLAC

Interruption at SLAC match sequence

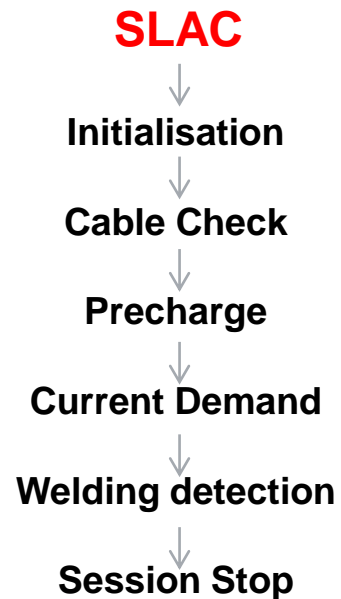

behaviour:

- EV interrupts after message CM_SLAC_Match.cnf is send by EVSE

analysis:

- Message CM_SLAC_Match.cnf is send as broadcast message

possible solution(s):

- Send message CM_SLAC_Match.cnf as unicast message according DIN SPEC 70121:2014-12, 8.3.3.3.2, Table 2

Failures during SLAC

Interruption after ChargeParameterDiscovery

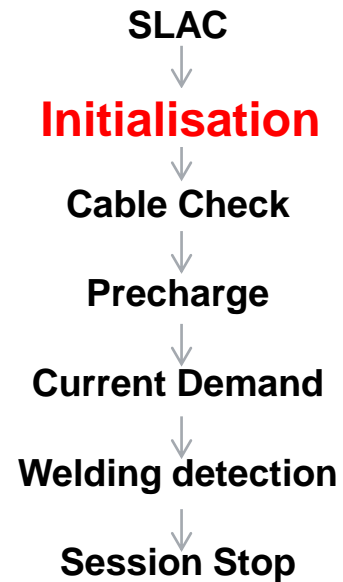

behaviour:

- EV interrupts after message ChargeParameterDiscovery.res is send by EVSE

analysis:

- Message ChargeParameterDiscovery.res does not contain the parameter EVSEMaxPowerLimit

possible solution(s):

- Implement the parameter EVSEMaxPowerLimit, which is mandatory in the message ChargeParameterDiscovery.res (DIN SPEC 70121:2014-12 [V2G-DC-626])

Failures during CurrentDemand sequence

Noise on pilot line

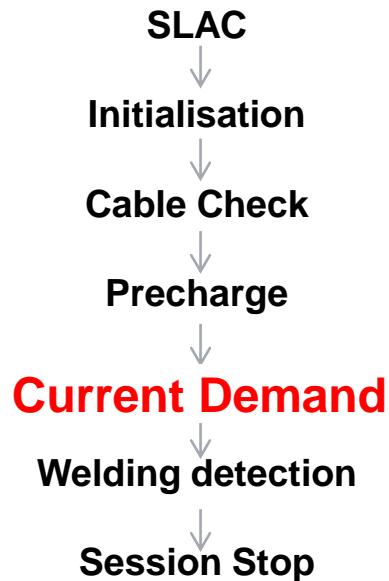

behaviour:

- EV interrupts after exchange of several CurrentDemand messages

analysis:

- Due to excessive noise on the pilot (CP), the EV detects a state change from state C to state B

possible solution(s):

- Improve EMC stability of the charger
- Implement some ferrit rings at the DC-output of the charger. DC+ and DC- cables have to be lead in parallel through the filter in the same direction for two or three turns
- Add filtering between the power part and the communication part of the charger Test EMC against IEC61851-21-2 (emission on charging cable)

Failures during CurrentDemand sequence

Interruption during CurrentDemand sequence I

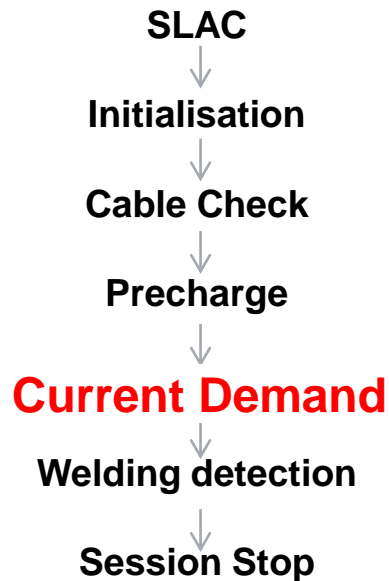

behaviour:

- EV interrupts after exchange of several CurrentDemand messages

analysis:

- EVSE is not able to manage CurrentDemand requests with higher current demand, before adjusting current from the older CurrentDemand.req message

possible solution(s):

- The EVSE has to process all current demand messages by the EV, even if they are send in short interval of time

Failures during CurrentDemand sequence

Interruption during CurrentDemand sequence II

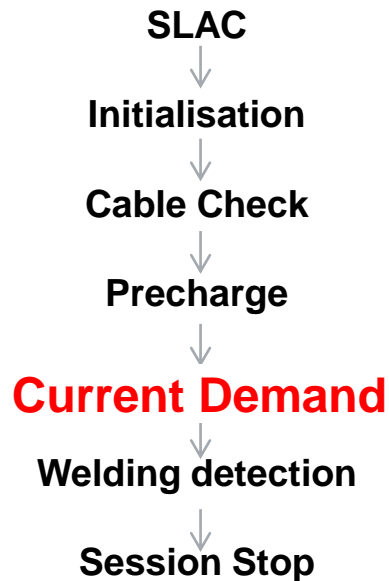

behaviour:

- EV interrupts during CurrentDemand Phase

analysis:

- EVSE sending CurrentDemand.res with a different value for current and /or voltage, than physically applied values

possible solution(s):

- Check, if voltage is measured after any diode or similar, directly as close as possible to the DC-output
- Check, if the measured values are send correctly in the CurrentDemand.req

Failures during CurrentDemand sequence

Interruption at the end of CurrentDemand sequence

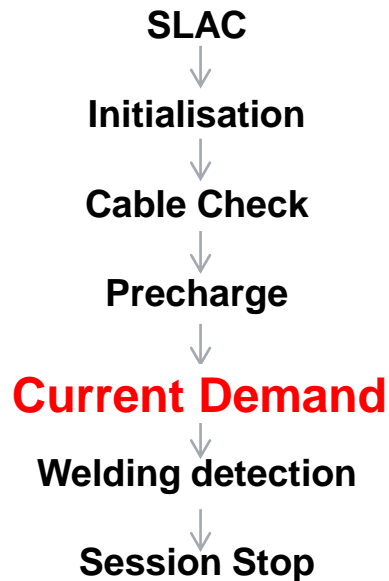

behaviour:

- EVSE interrupts the charging process before reaching 100% SOC

analysis:

- possibility 1:
EVSE interrupts, because the minimum charging current from EVSE is too high (e.g. 5A)
- possibility 2:
EVSE interrupts charging, because charging time has expired

possible solution(s):

1. Change the lowest possible charging current to 1A
2. Do not use charging time as an abort criterion

Agenda

1 Introduction

2 Illustration of Supply Sequence

3 Illustration of Pulse Width Modulation

4 Illustration of SLAC Sequence

5 Illustration of High Level Communication

6 Potential failures within charging sequence (DINSpec 70121 implemented)

7 Safety Concept for Potential Failures within Supply Sequence

8 Additional key points for EVSE's

9 Relevant Standards

Functional Overview of the Combined Charging System

The Functional Overview shows potential failures within the Combined Charging System and their effects as well as the detection and mitigation.

Description

- Based on general risks and potential failures the complete set of functions of the combined charging system have been investigated.
- The following functional overview is a complete description of all charging sequences. It contains
 - the system operation behavior and its reflection to High-Level Functions,
 - systematic identification of potential failures and specific risks,
 - potential effects of failure, their detection, mitigation and the reference to the applicable clauses in standards.

Example

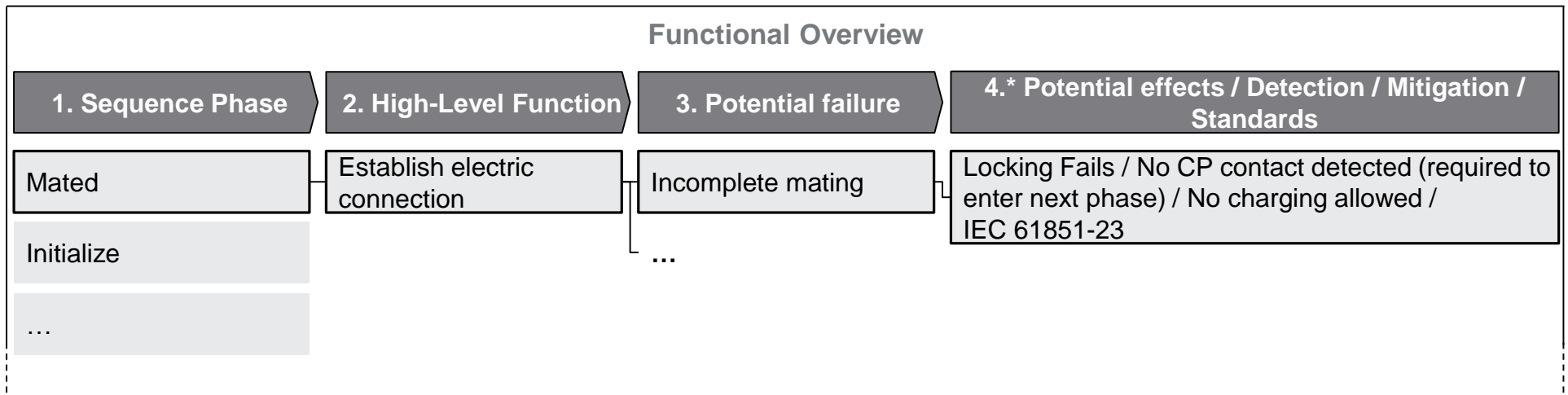

* simplified system activity

Exit Strategy

The defined Exit Strategy leads to the prevention of safety risks as the charging sequence can be terminated under certain conditions.

Description

- In order to prevent safety risks, the charging sequence shall be terminated at this point under certain conditions.

Terminated before energy started

- If the energy transfer has not started yet, the sequence will be simply stopped such that the next phase will not be entered. In the following slides, this is used as Mitigation: “No charging allowed” and will end in a safe state:

No charging started → Safe State

Terminated after energy started

- If the energy transfer has already started, the charging process would have to be terminated.
- This is **ALWAYS** a cascading chain of action that features several entry levels (3 level exit strategy):

1. Normal Shutdown via PLC, current ramp down at max. 100A/s in a standardized time window. If this is not successful, the next level will be triggered automatically.

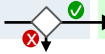
Level 1: Normal Shutdown  Safe State

2. Emergency Shutdown via pilot, initiated by EV (Pilot-> B2) or station (Pilot -> B1), current ramp down at min. 200A/s in a standardized time window. If this is not successful, the next level will be triggered automatically.

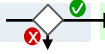
Level 2: Emergency Shutdown  Safe State

3. Vehicle disconnects via disconnecting device. Designed for disconnection under load.

Level 3: Vehicle disconnects via disconnecting device → Safe State

Sequence Phase: Mated

Certain failures have been identified for the following phase.
The failure prevention measures/exit strategies will lead to a safe state.

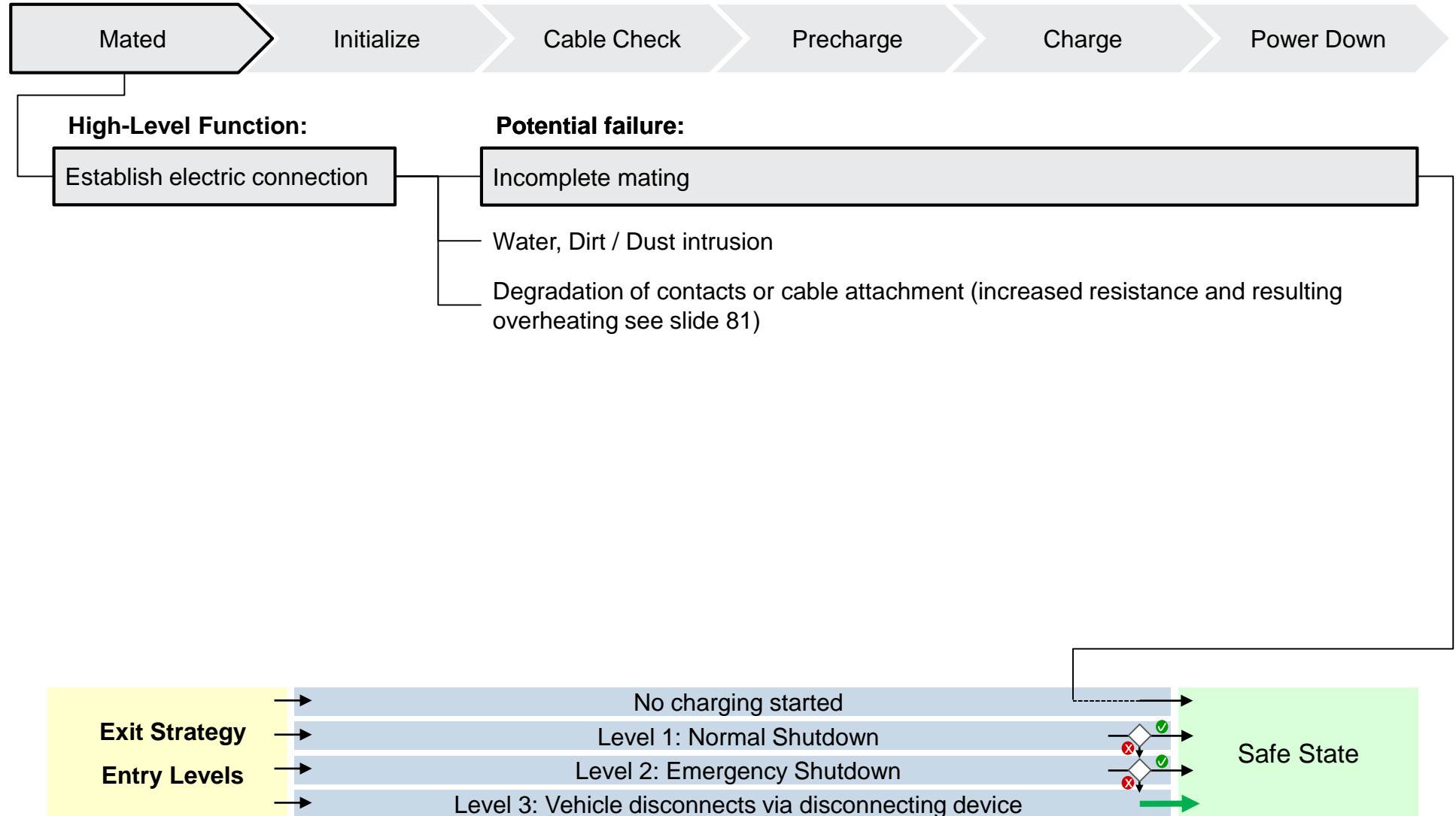

Potential Failure: Incomplete Mating

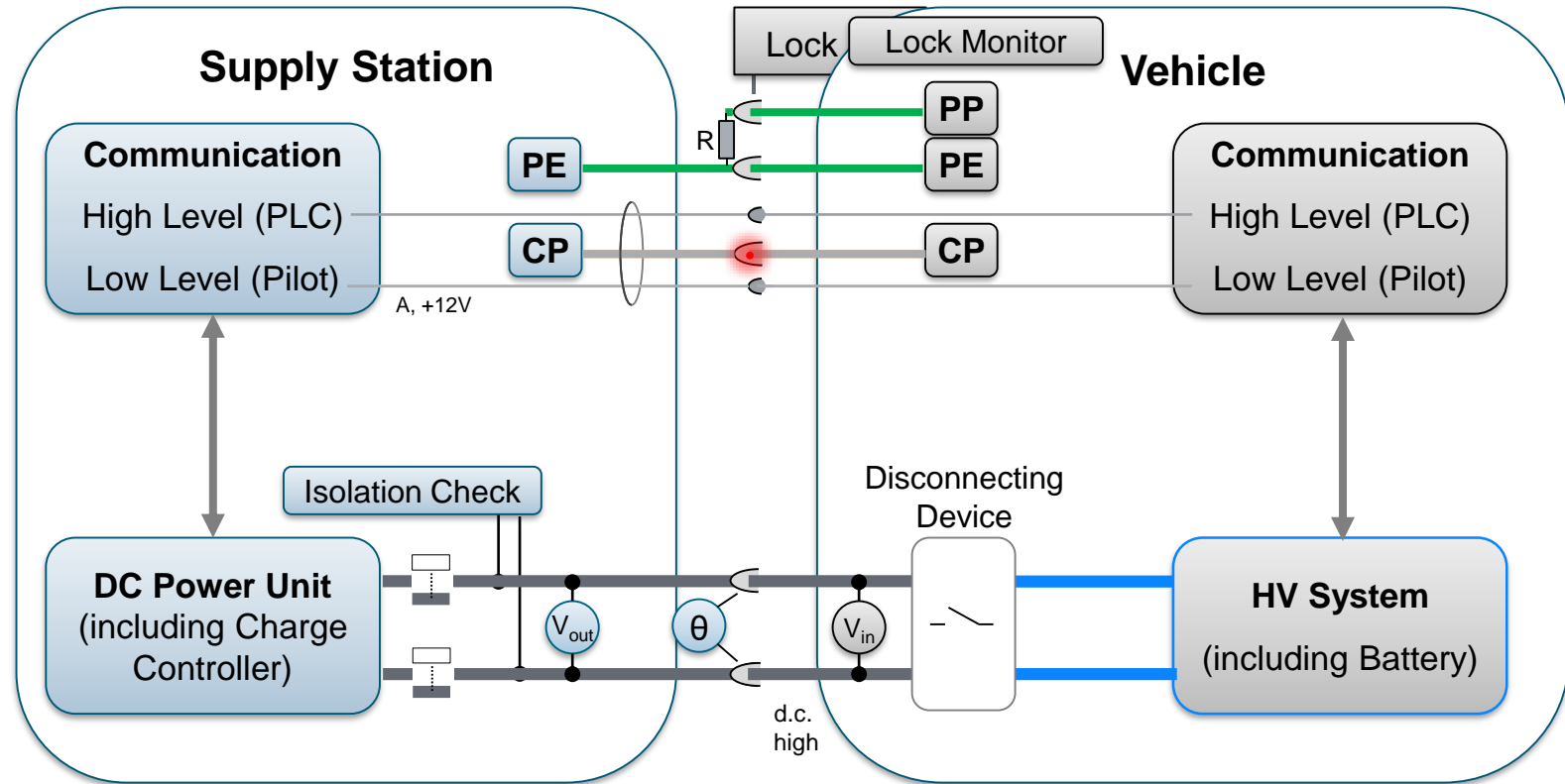

- Potential Effect: Overlapping of contacts not sufficient, reduced current capability
- Detection: No CP contact detected (required to enter next phase)
- Mitigation: No charging started
- Standard Ref: IEC 61851-23 CC.1a (t0) and IEC61851-23 CC.1, CC.2, CC.3, CC.4

Sequence Phase: Mated

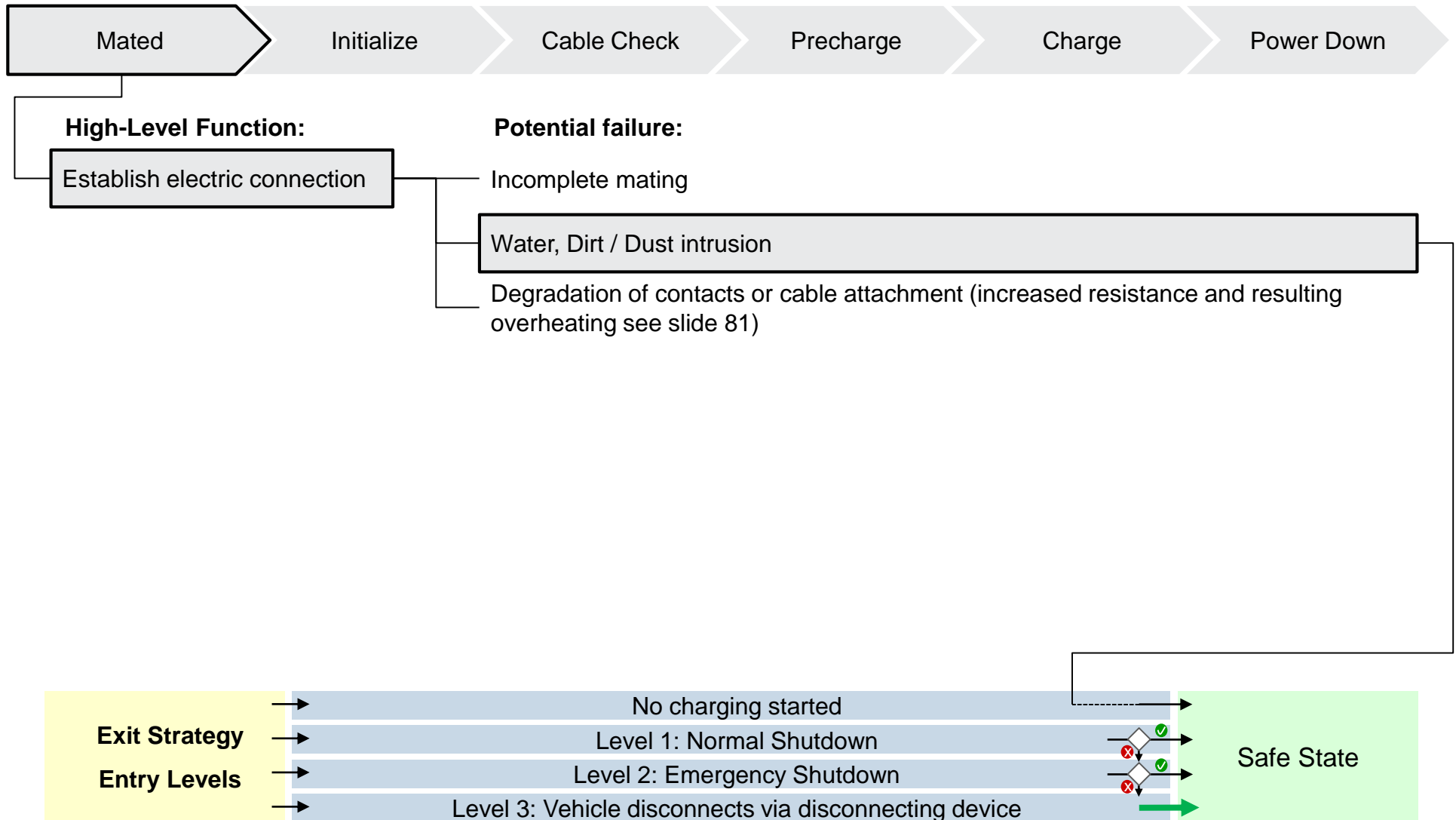

Potential Failure: Water, Dirt or Dust Intrusion

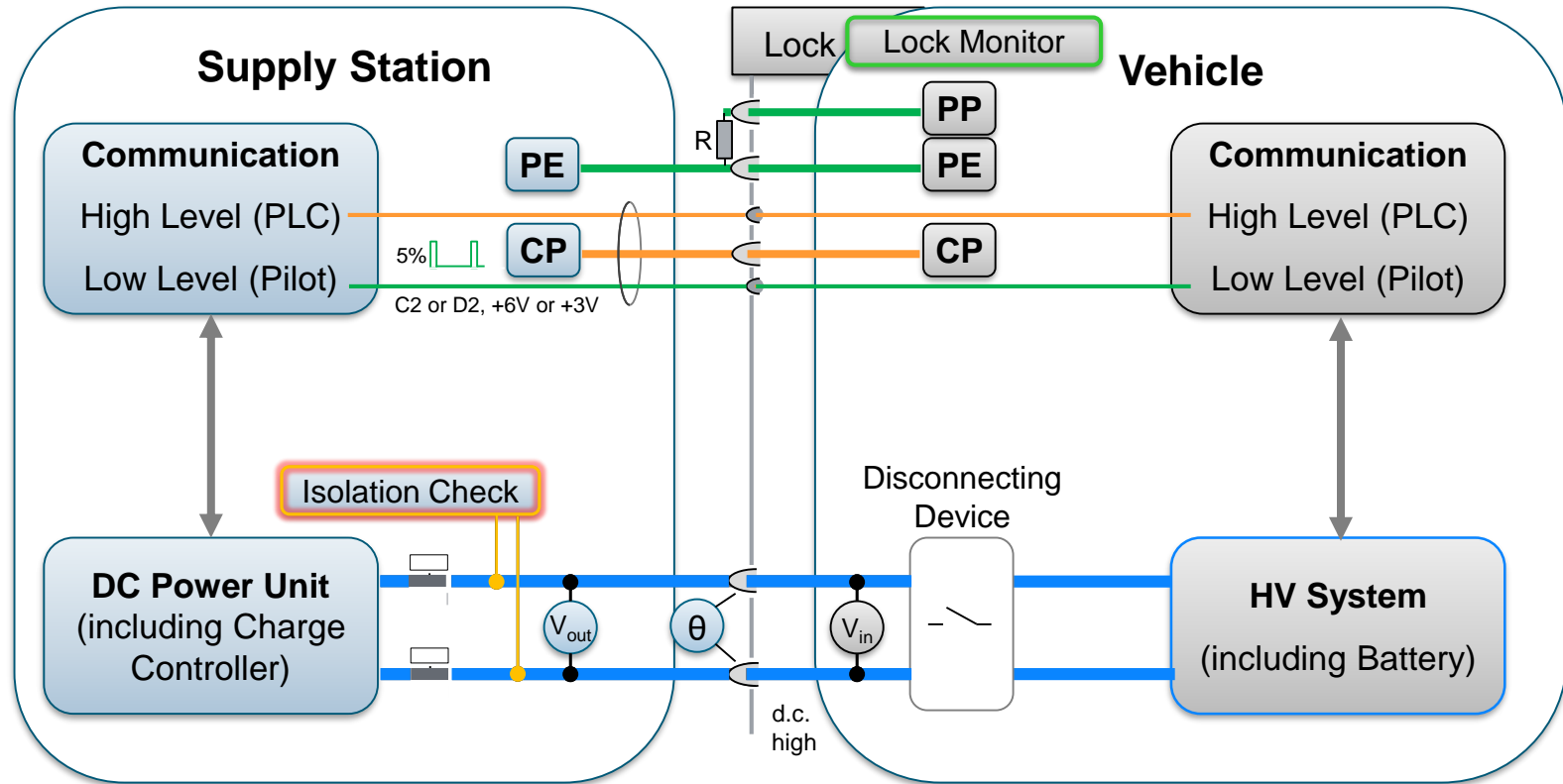

- Potential Effect: Insulation resistance decreases
- Detection: Isolation Check is performed by Supply Station including self test
- Mitigation: Isolation Check = fault -> no charging started (Drainage in Inlet. Coupler (plugged system) = IP44)
- Standard Ref: Isolation Check IEC 61851-23, CC.5.1, IP44 IEC 62196-1 11.3.1

Sequence Phase: Mated

Certain failures have been identified for the following phase.
The failure prevention measures/exit strategies will lead to a safe state.

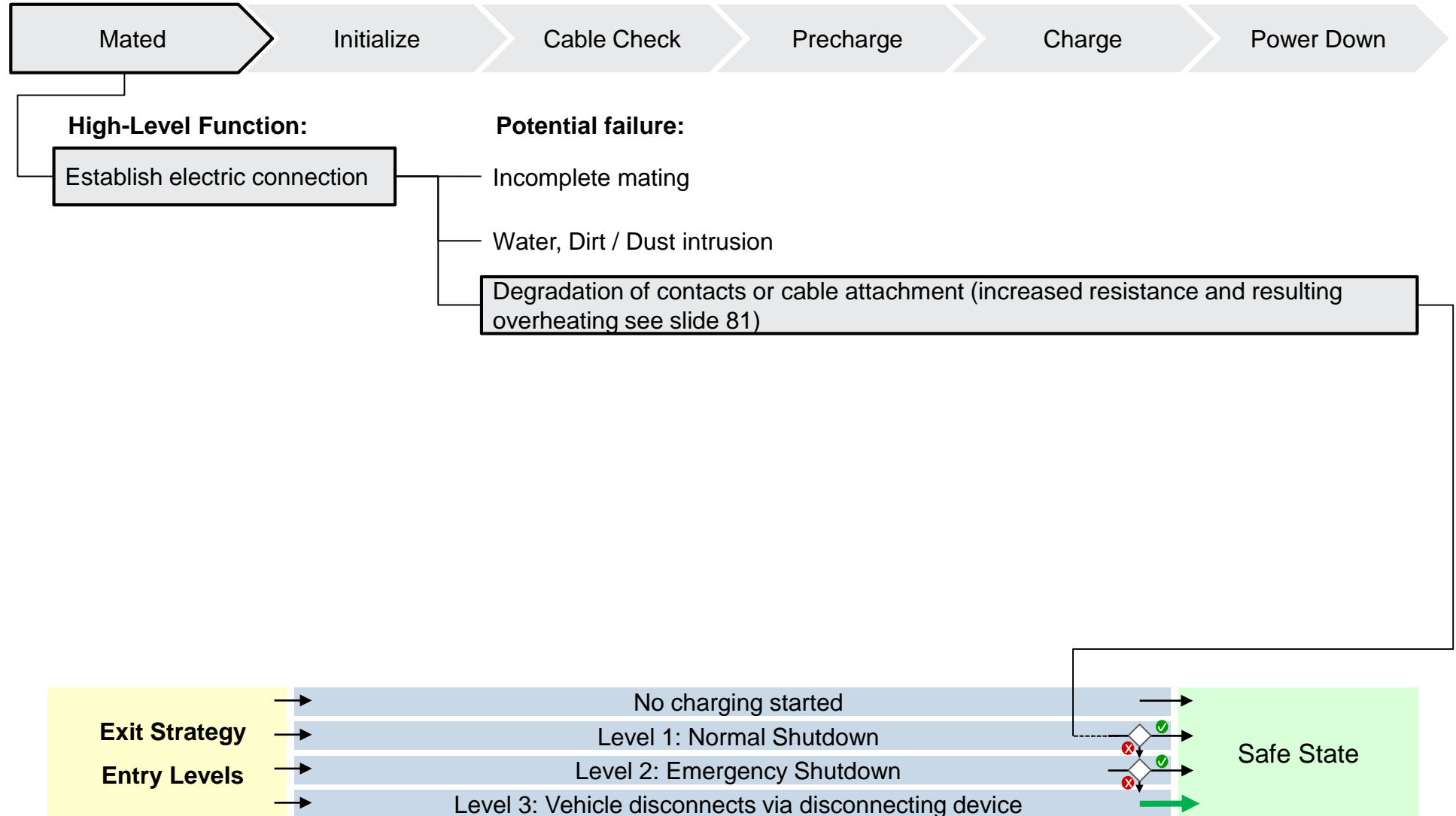

Sequence Phase: Initialize

Certain failures have been identified for the following phase.
The failure prevention measures/exit strategies will lead to a safe state.

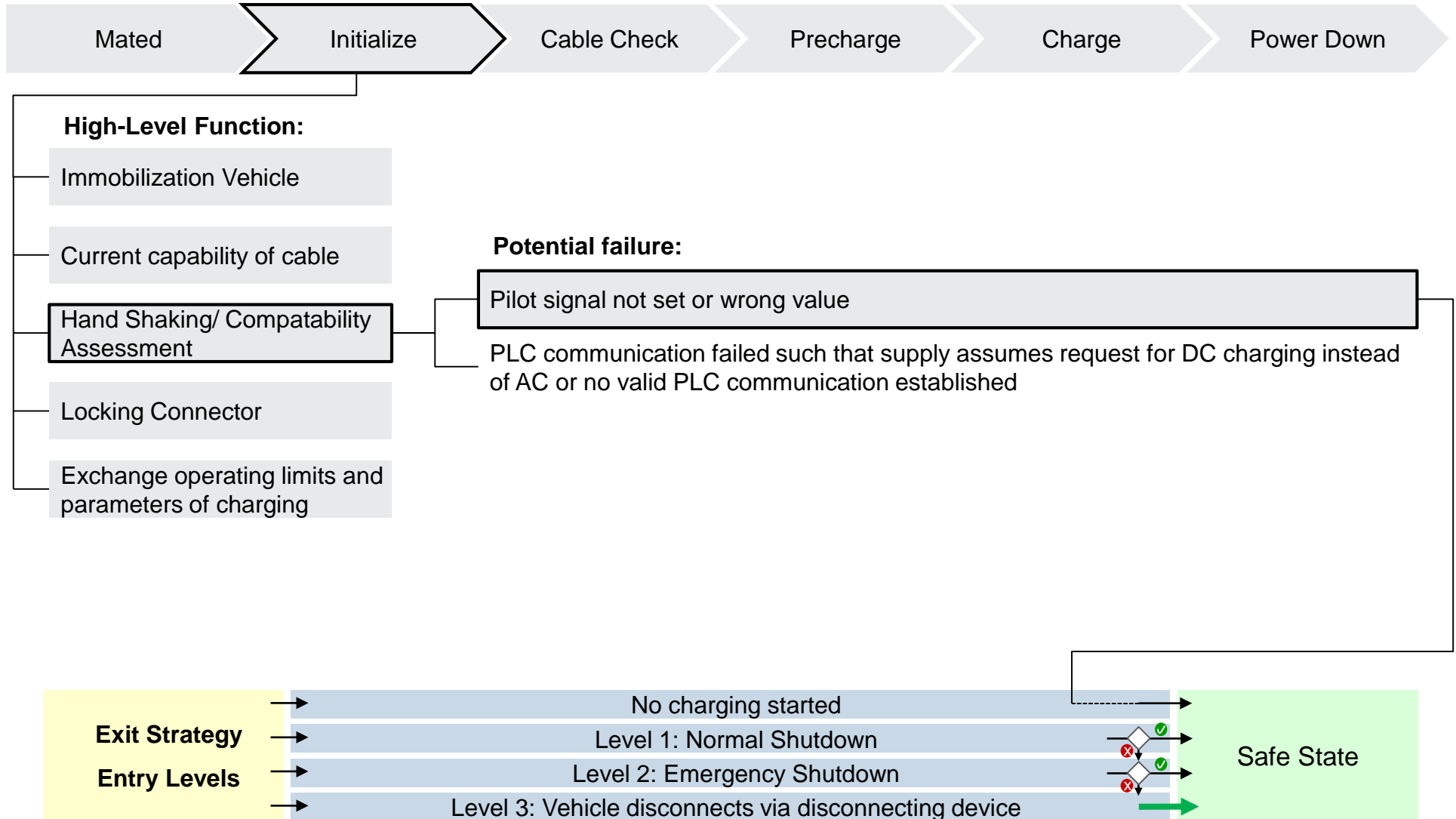

Potential Failure: Pilot Signal not set or Wrong Value

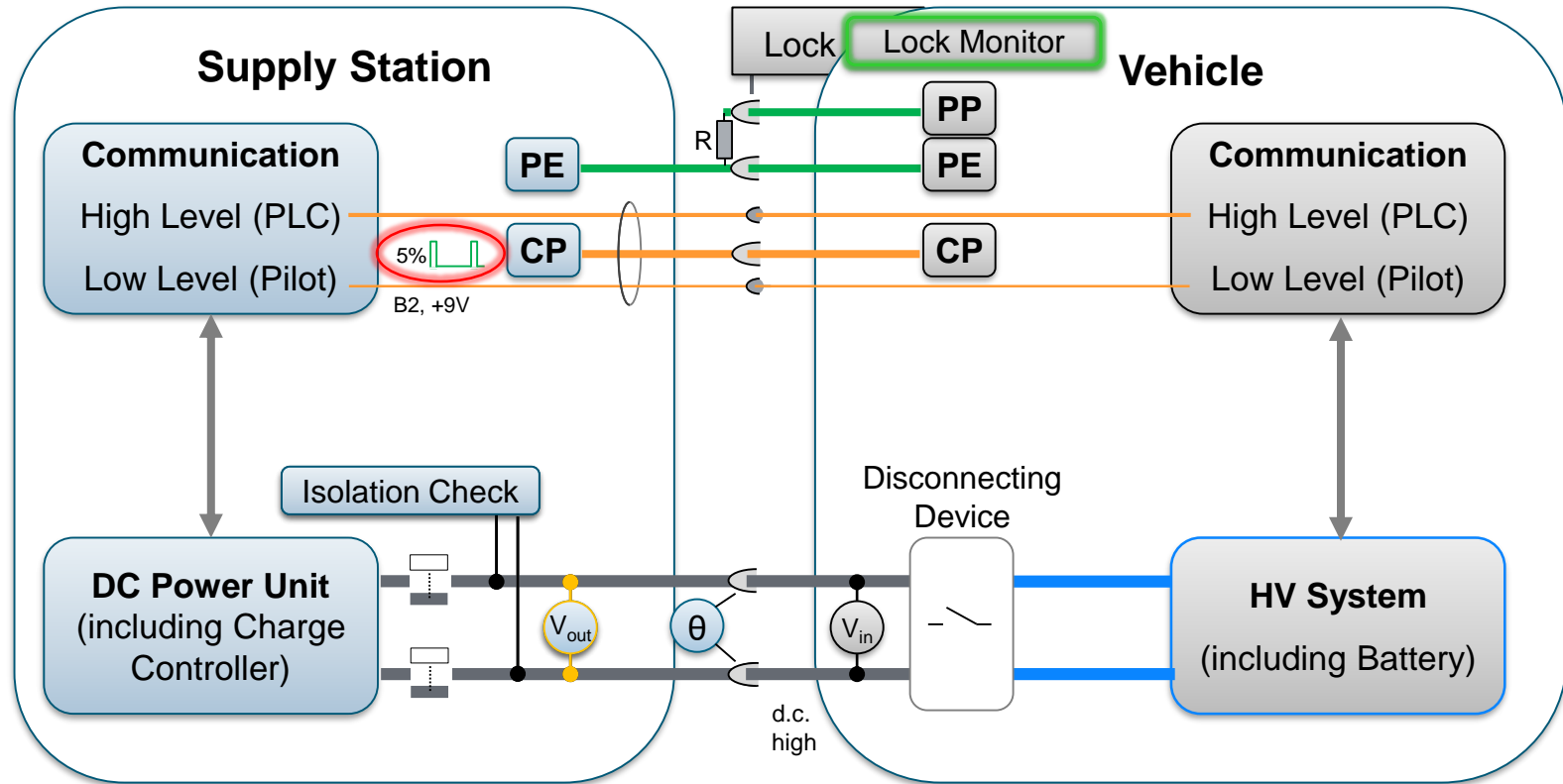

- Potential Effects: No or invalid pilot signal
- Detection: Vehicle validates signal against standardized definitions
- Mitigation: No charging started
- Standard Ref: IEC 61851-23, CC.1a time stamp t_0/t_4 and IEC61851-23 CC.1, CC.2, CC.3, CC.4

Sequence Phase: Initialize

Certain failures have been identified for the following phase.
The failure prevention measures/exit strategies will lead to a safe state.

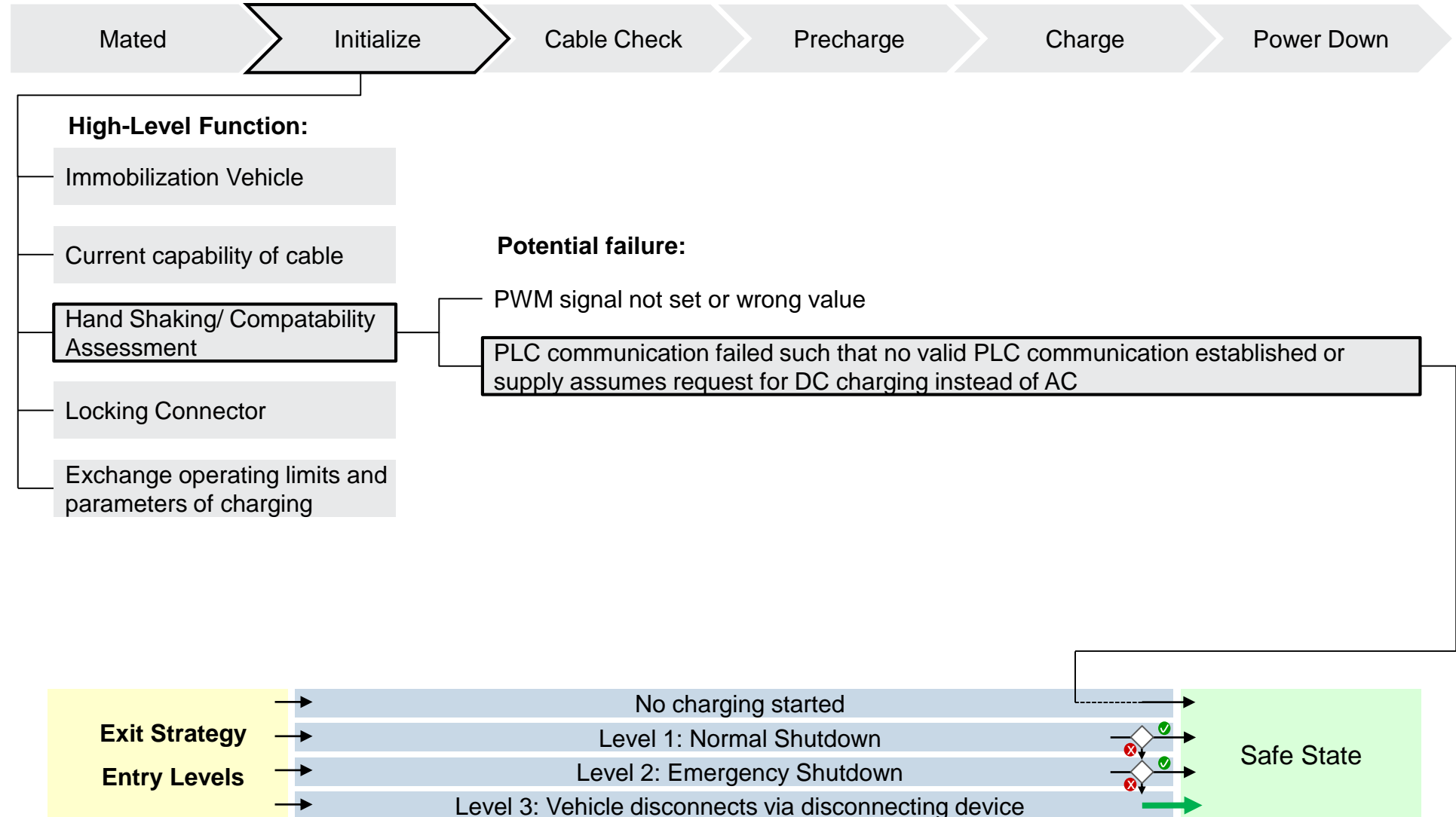

Potential Failure: PLC Communication Failed or Incompatible

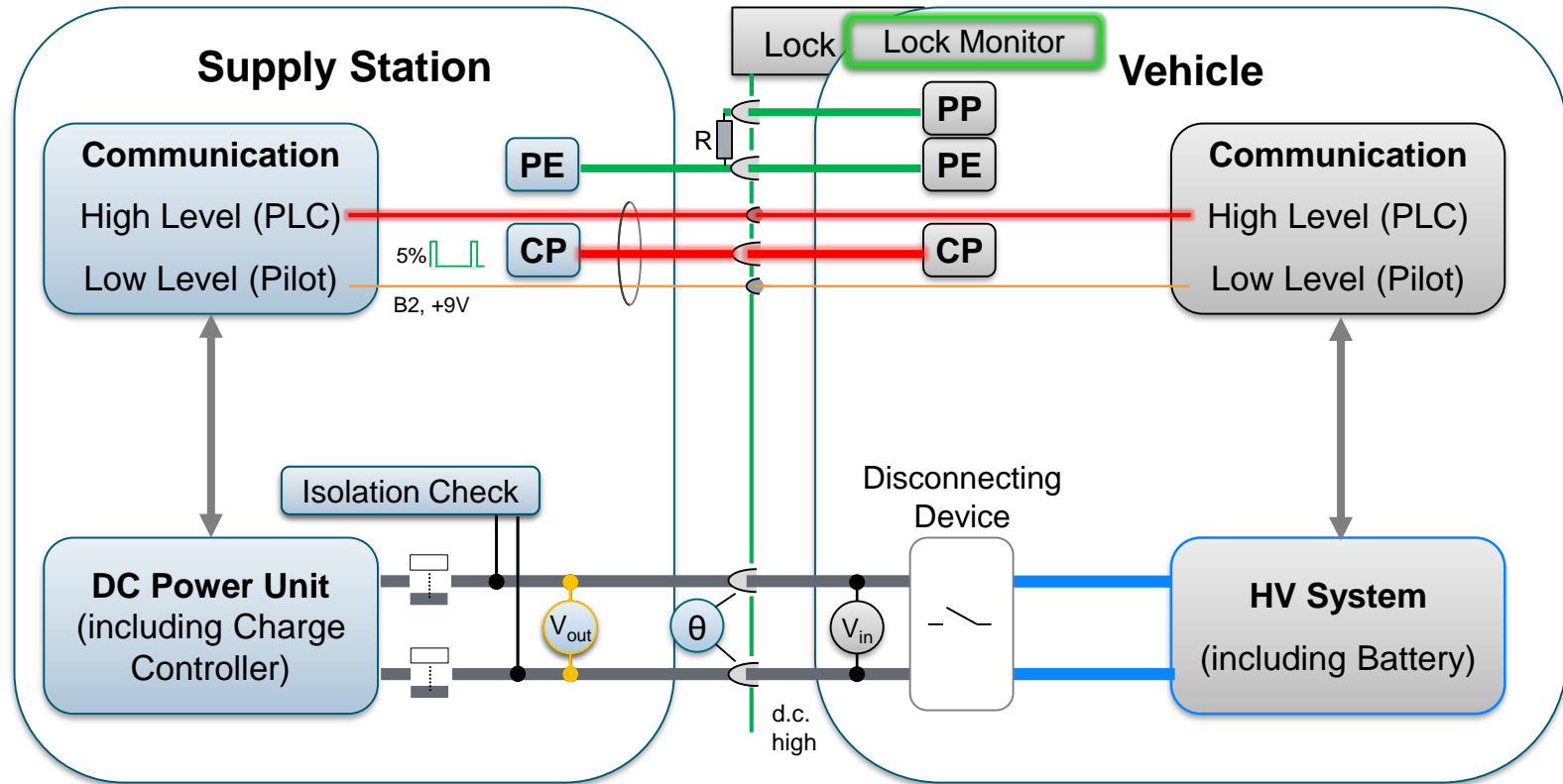

- Potential Effects: Misinterpretation or incompatibility of PLC information
- Detection: Compatibility check (version based)
- Mitigation: No charging started
- Standard Ref: ISO/IEC 15118-2 ¹⁾

¹⁾ In conjunction with ISO/IEC 15118 please note also DIN SPEC 70121.

Sequence Phase: Initialize

Certain failures have been identified for the following phase.
The failure prevention measures/exit strategies will lead to a safe state.

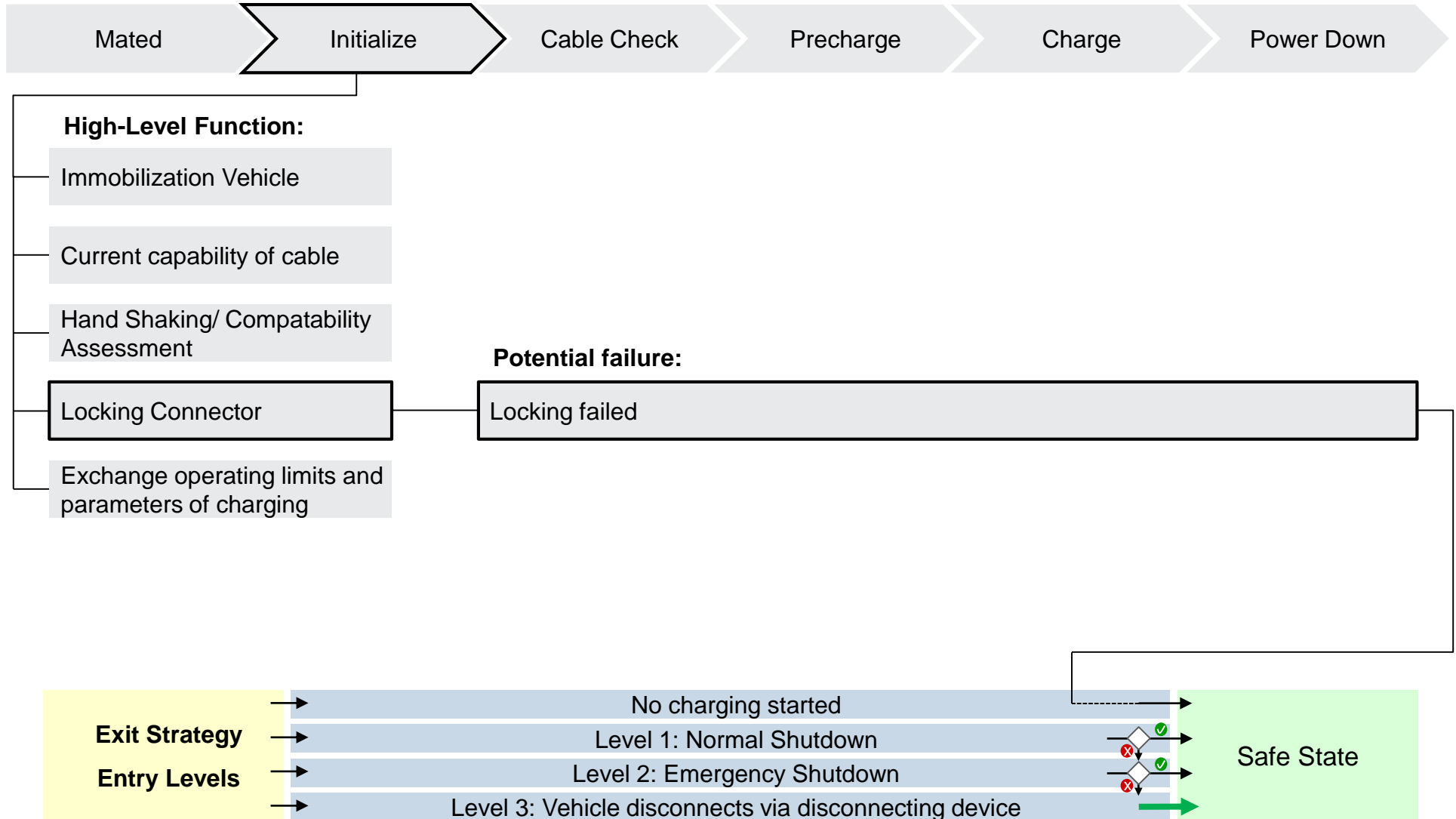

Potential Failure: Locking Failed

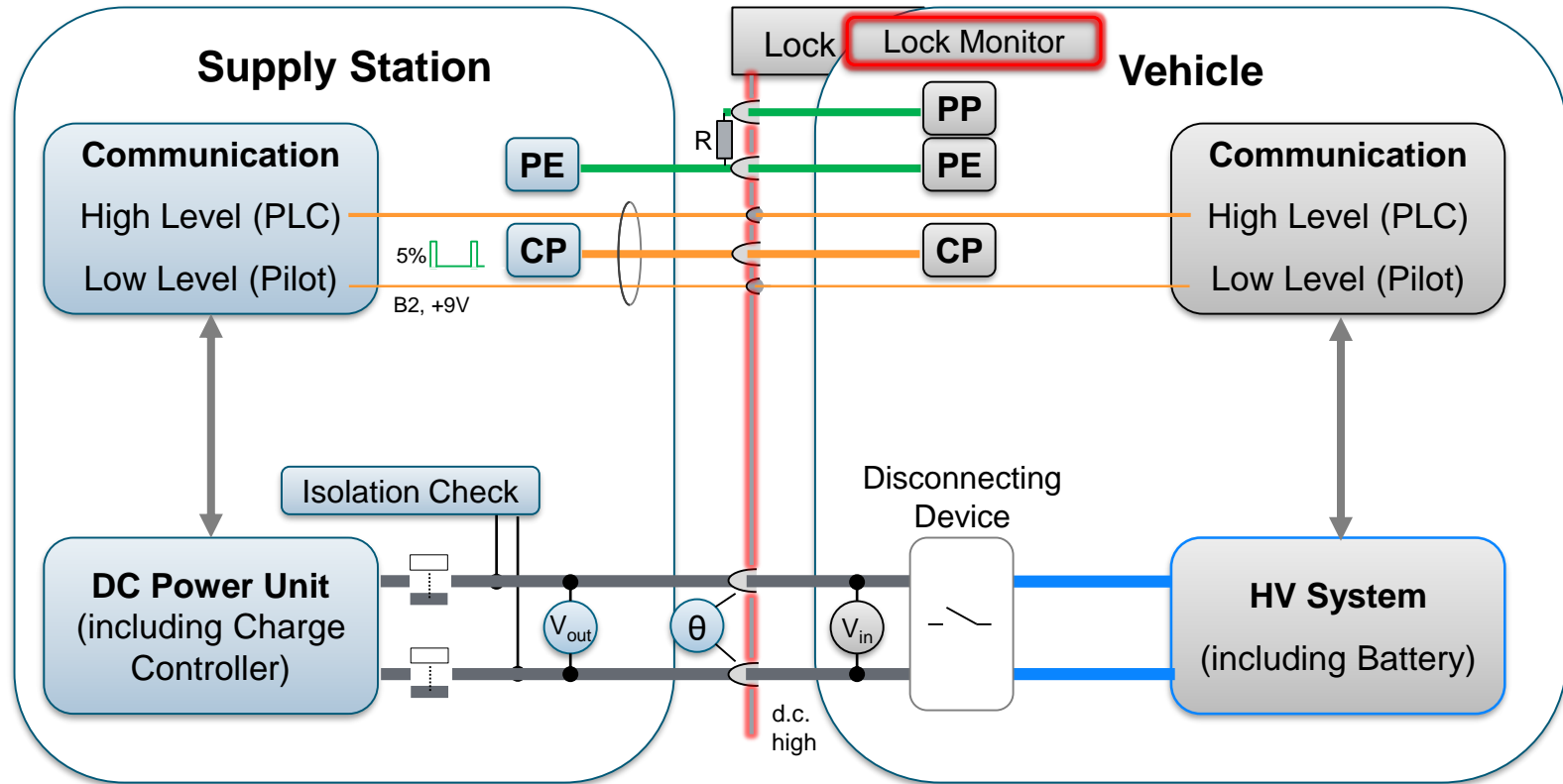

- Potential Effect: Connector is not locked and can be removed
- Detection: Lock monitoring signals error
- Mitigation: No charging started
- Standard Ref: IEC 62196-3, 16.301, ISO 17409 Clause 9, IEC 61851-23 CC.5.3

Sequence Phase: Initialize

Certain failures have been identified for the following phase.
The failure prevention measures/exit strategies will lead to a safe state.

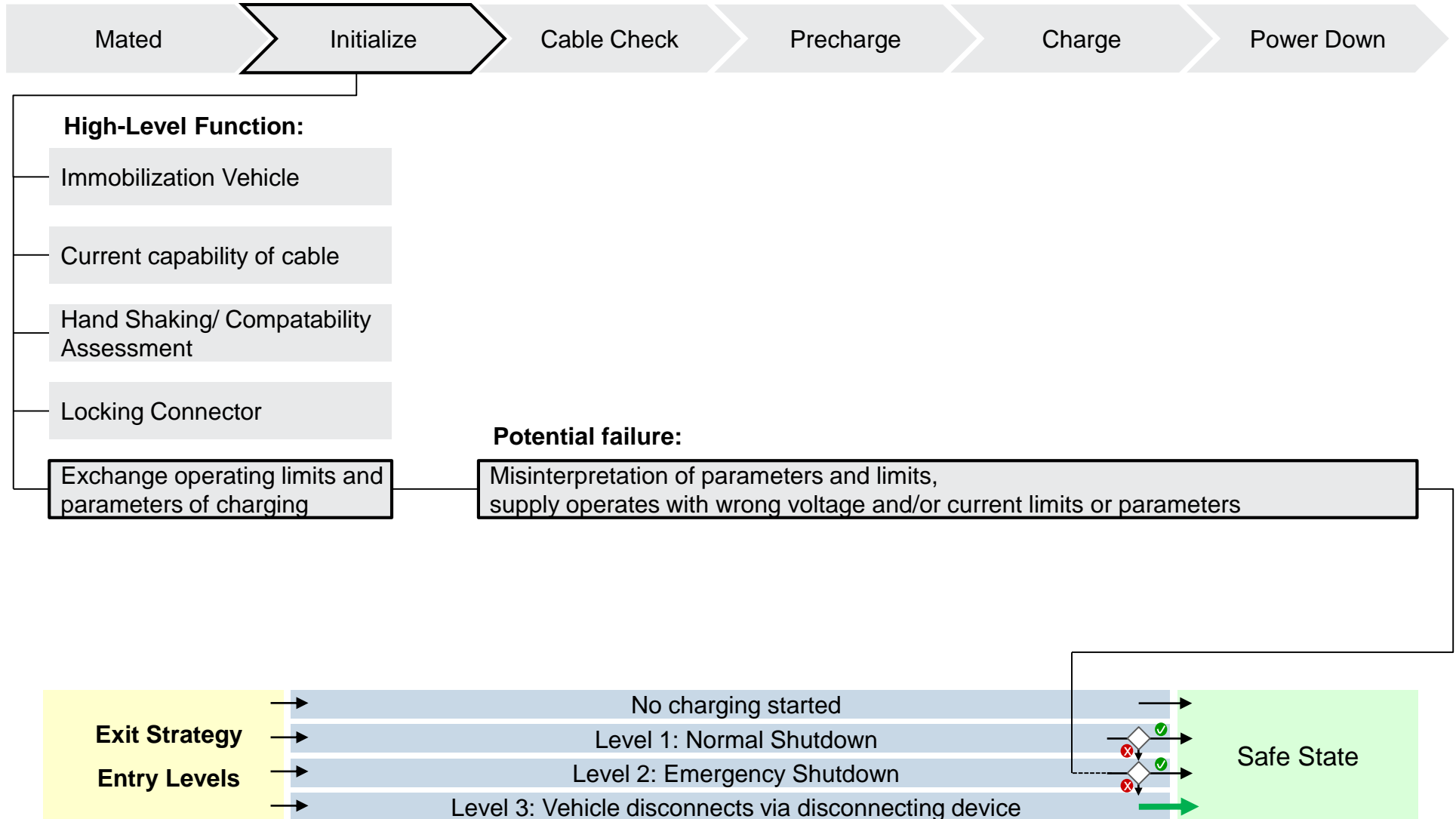

Potential Failure: PLC Communication Error: Misinterpretation of Parameters and Limits

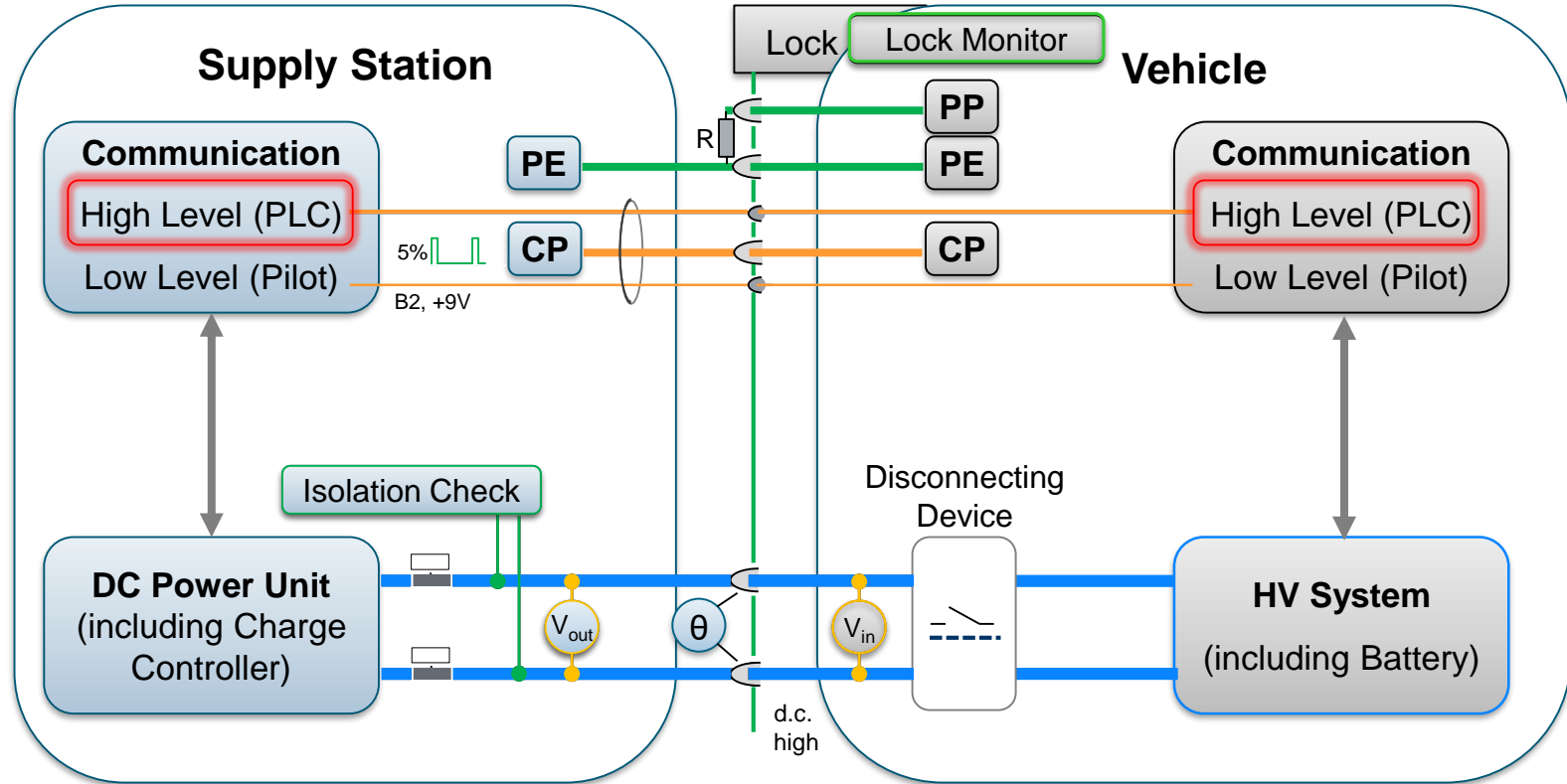

- Potential Effects : Later during charging: 1) Overvoltage, 2) Overcurrent, 3) Reverse current
- Detection: 1&2) Voltage and current measurement during charging
- Mitigation: 1&2) EV initiated emergency shutdown. 3) Prohibited and ensured by supply
- Standard Ref: IEC 61851-23 CC for 1 and 2, IEC 61851-23 101.1.5 for 3

Sequence Phase: Cable Check

Certain failures have been identified for the following phase.
The failure prevention measures/exit strategies will lead to a safe state.

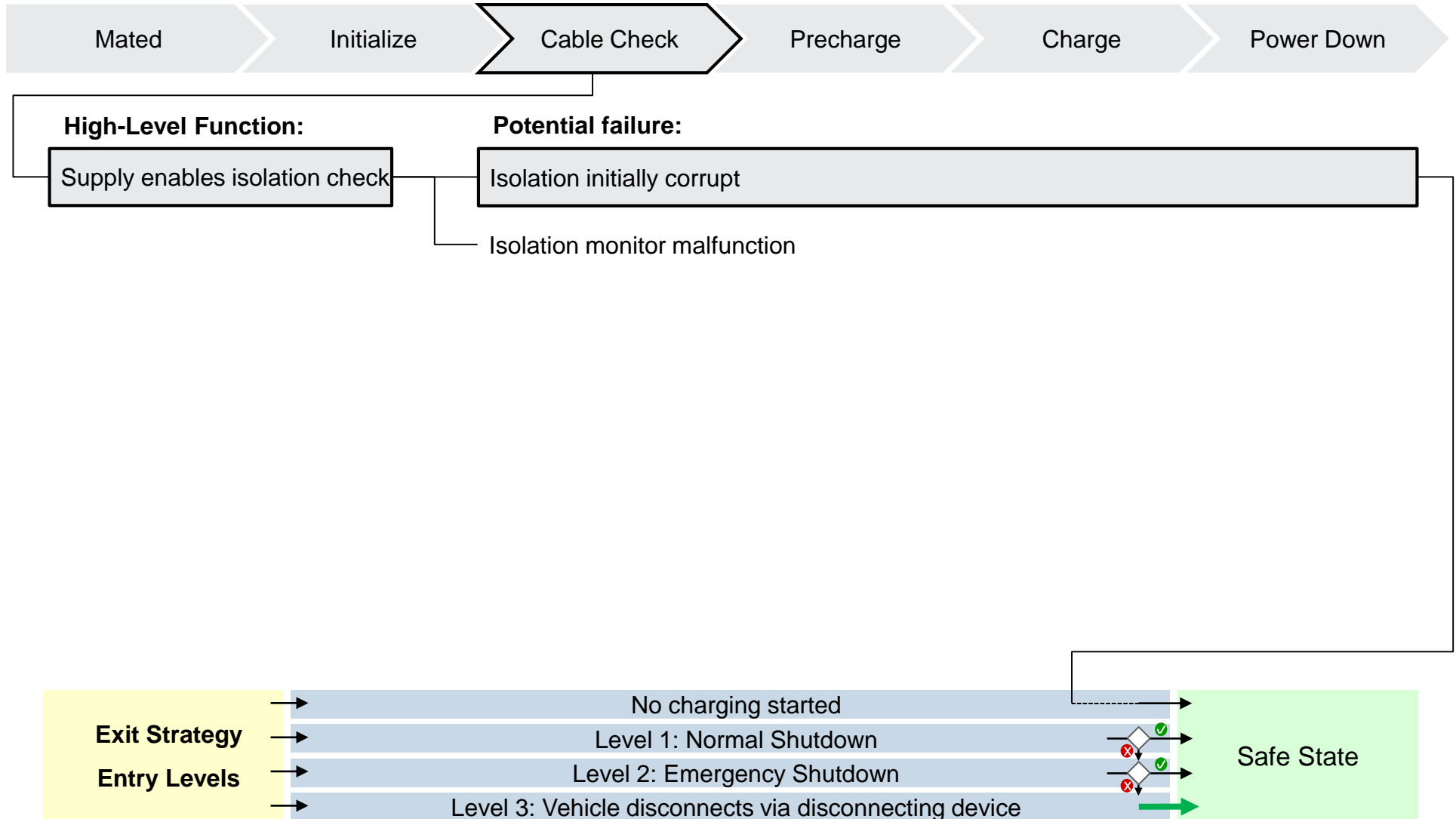

Potential Failure: Isolation Initially Corrupt

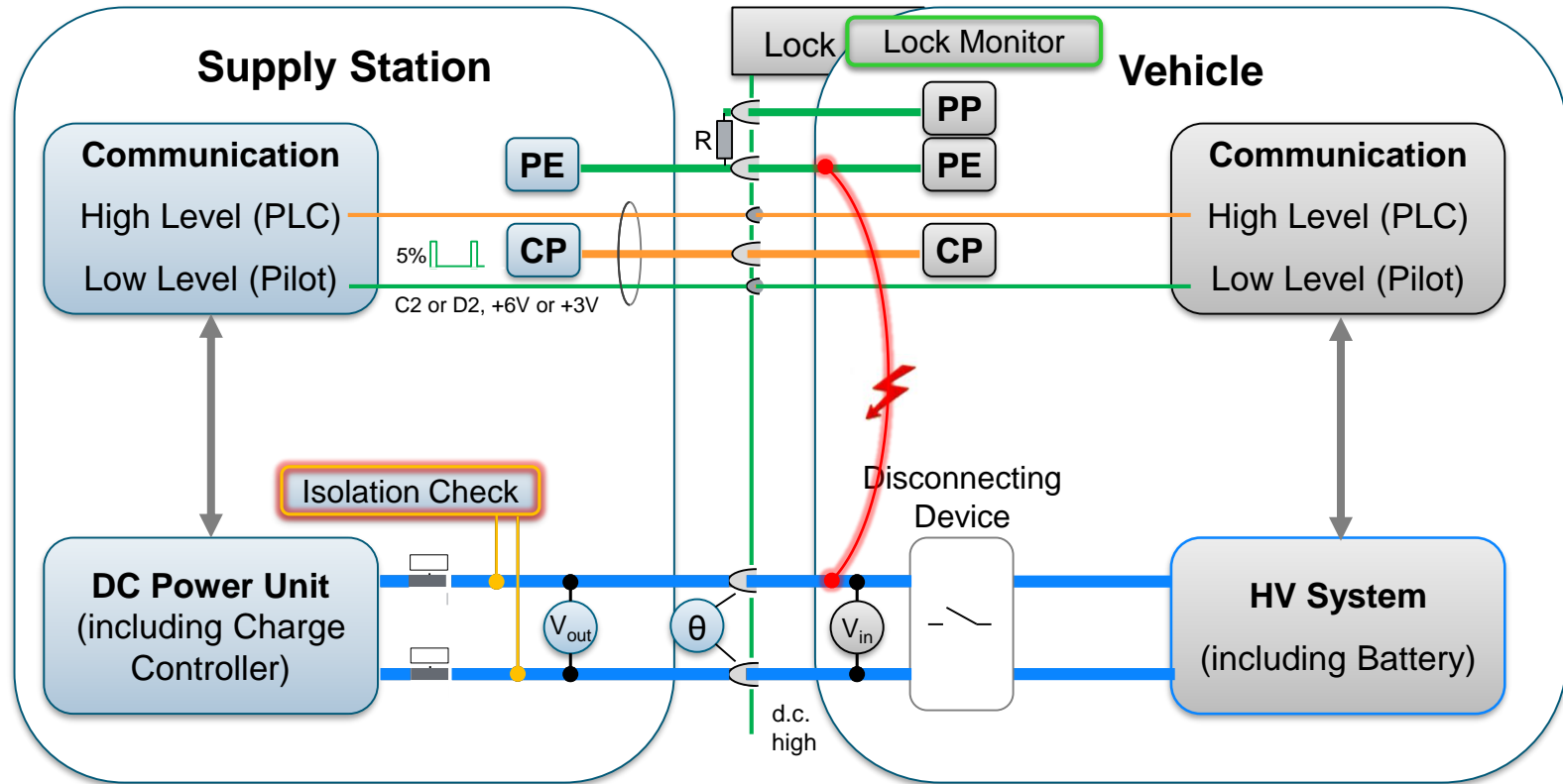

- Potential Effects: Connection between HV system and supply may lead to strike or arc
- Detection: Perform initial isolation check at 500V (mandatory for supply, optional for vehicle)
- Mitigation: No charging started
- Standard Ref: IEC 61851-23, CC5.1

Sequence Phase: Cable Check

Certain failures have been identified for the following phase.
The failure prevention measures/exit strategies will lead to a safe state.

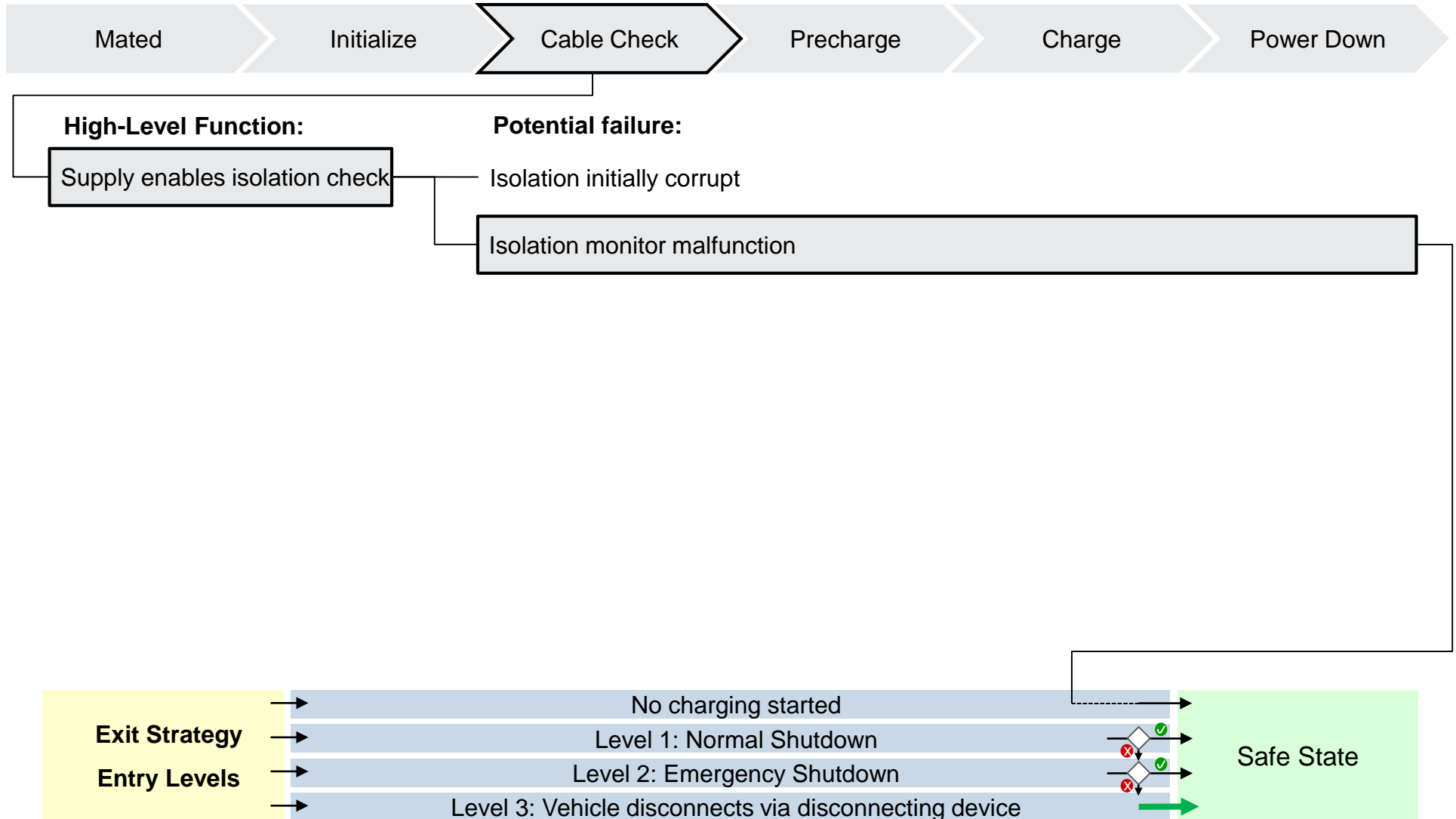

Potential Failure: Isolation Monitor Malfunction

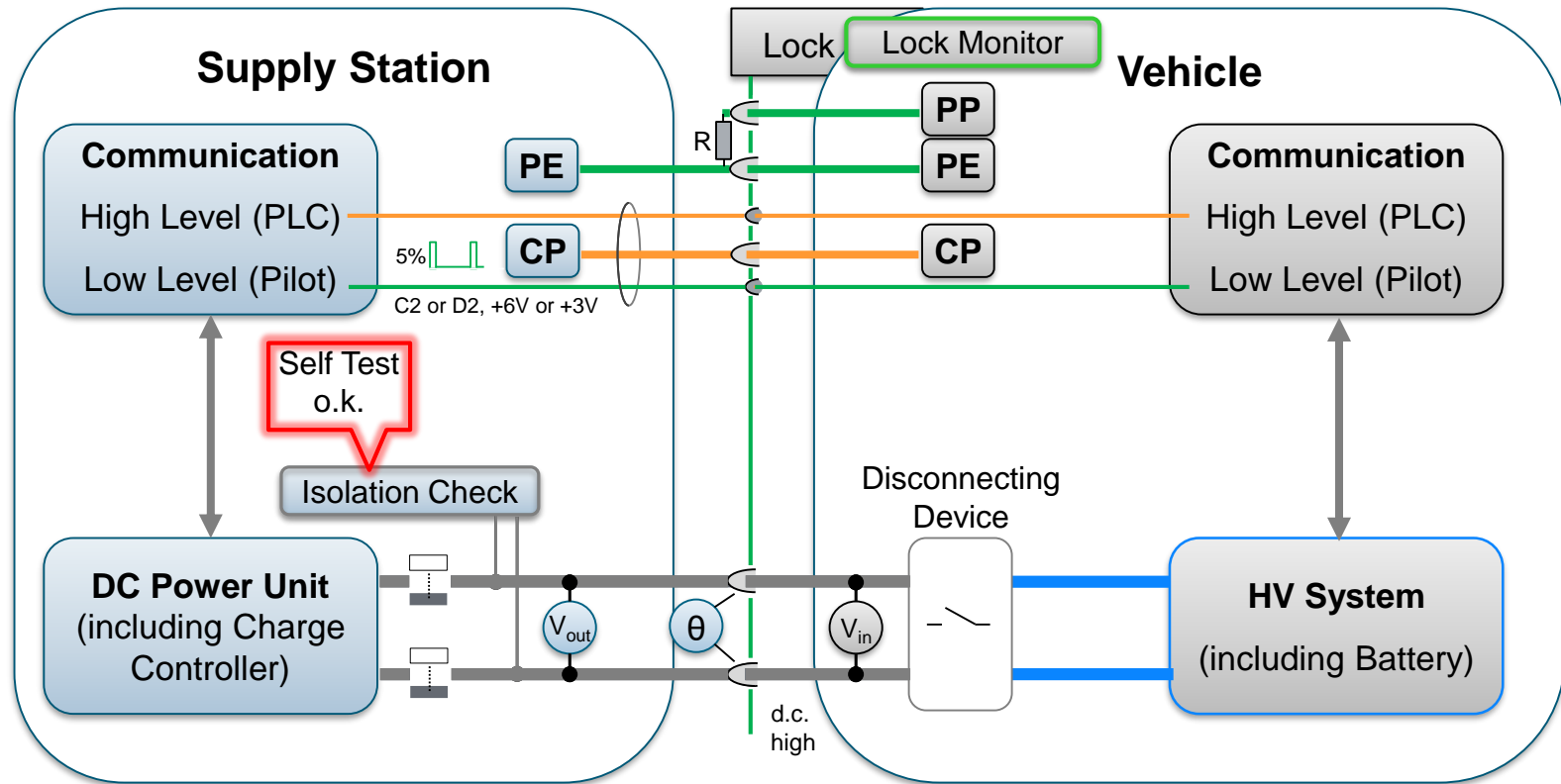

- Potential Effects: Corrupted isolation not detected.
- Detection: Perform isolation monitor self test
- Mitigation: No charging started
- Standard Ref: IEC 61851-23, CC5.1

Sequence Phase: Precharge

Certain failures have been identified for the following phase.
The failure prevention measures/exit strategies will lead to a safe state.

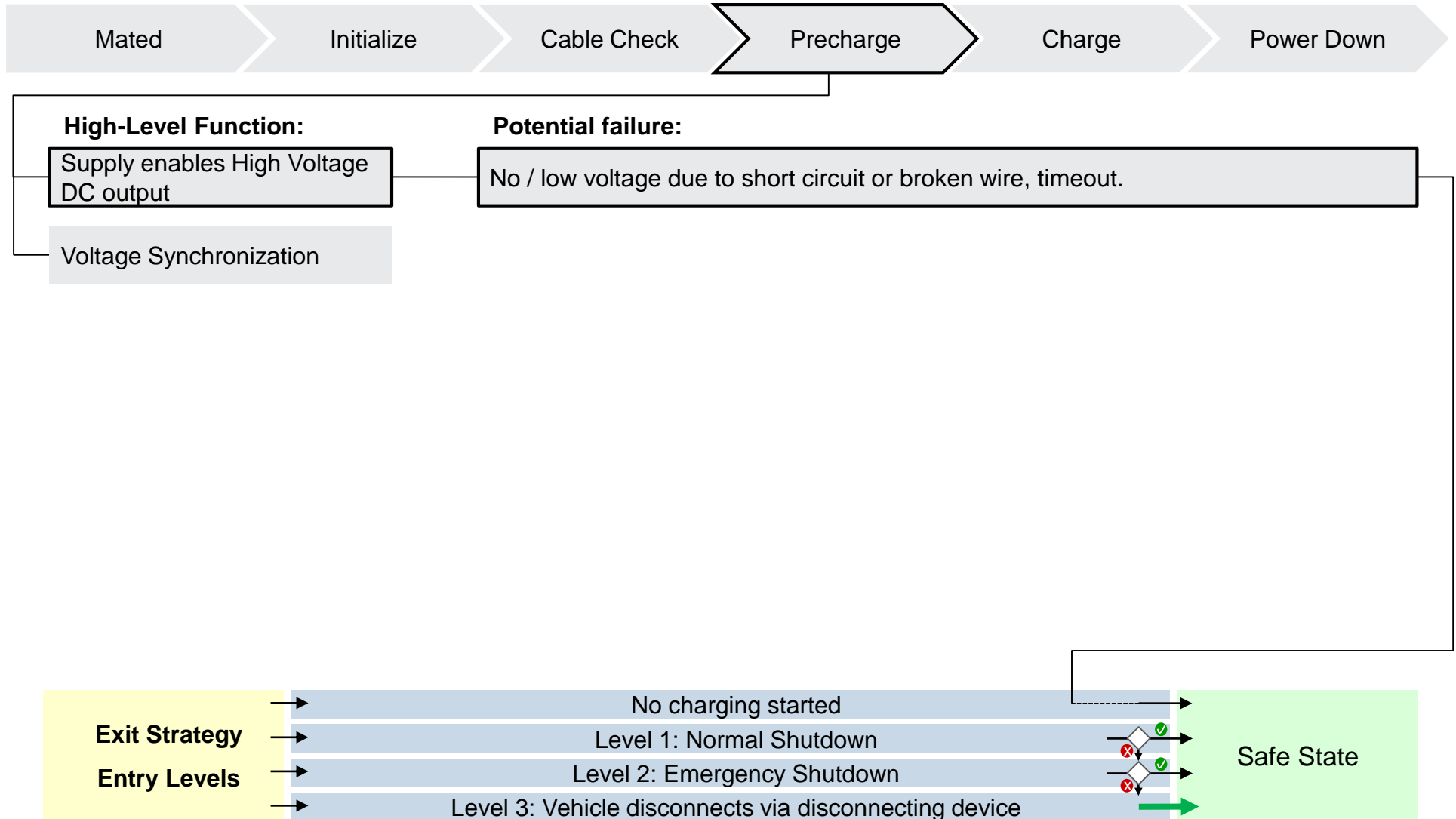

Potential Failure: Cable Defect – Short Circuit or Broken Wire

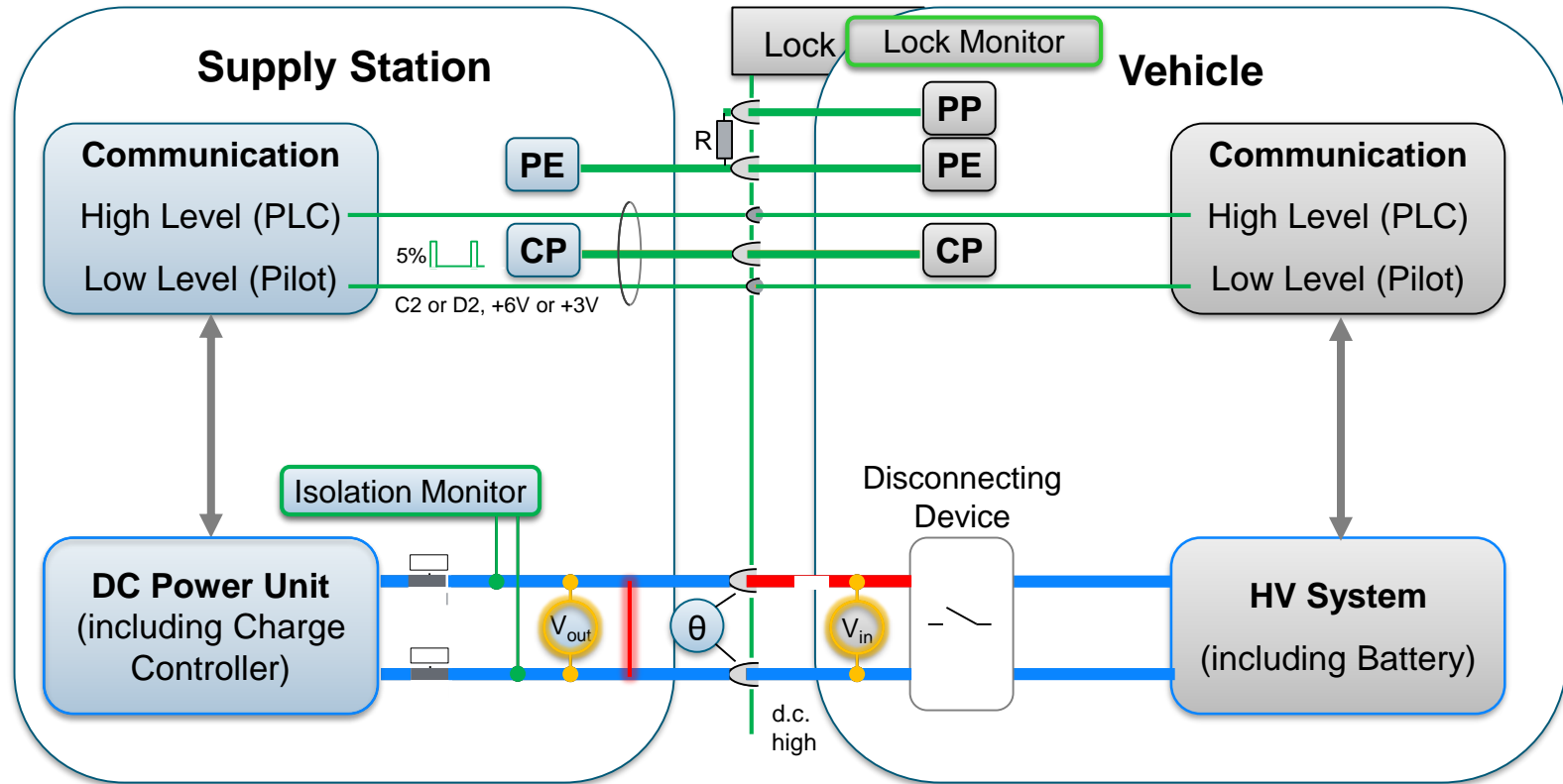

- Potential Effect: Precharge voltage cannot be established
- Detection: Voltage measurement
- Mitigation: Timeout error, no charging started
- Standard Ref: ISO 17409 13.4.1, IEC 61851-23, 6.4.3.110

Sequence Phase: Precharge

Certain failures have been identified for the following phase.
The failure prevention measures/exit strategies will lead to a safe state.

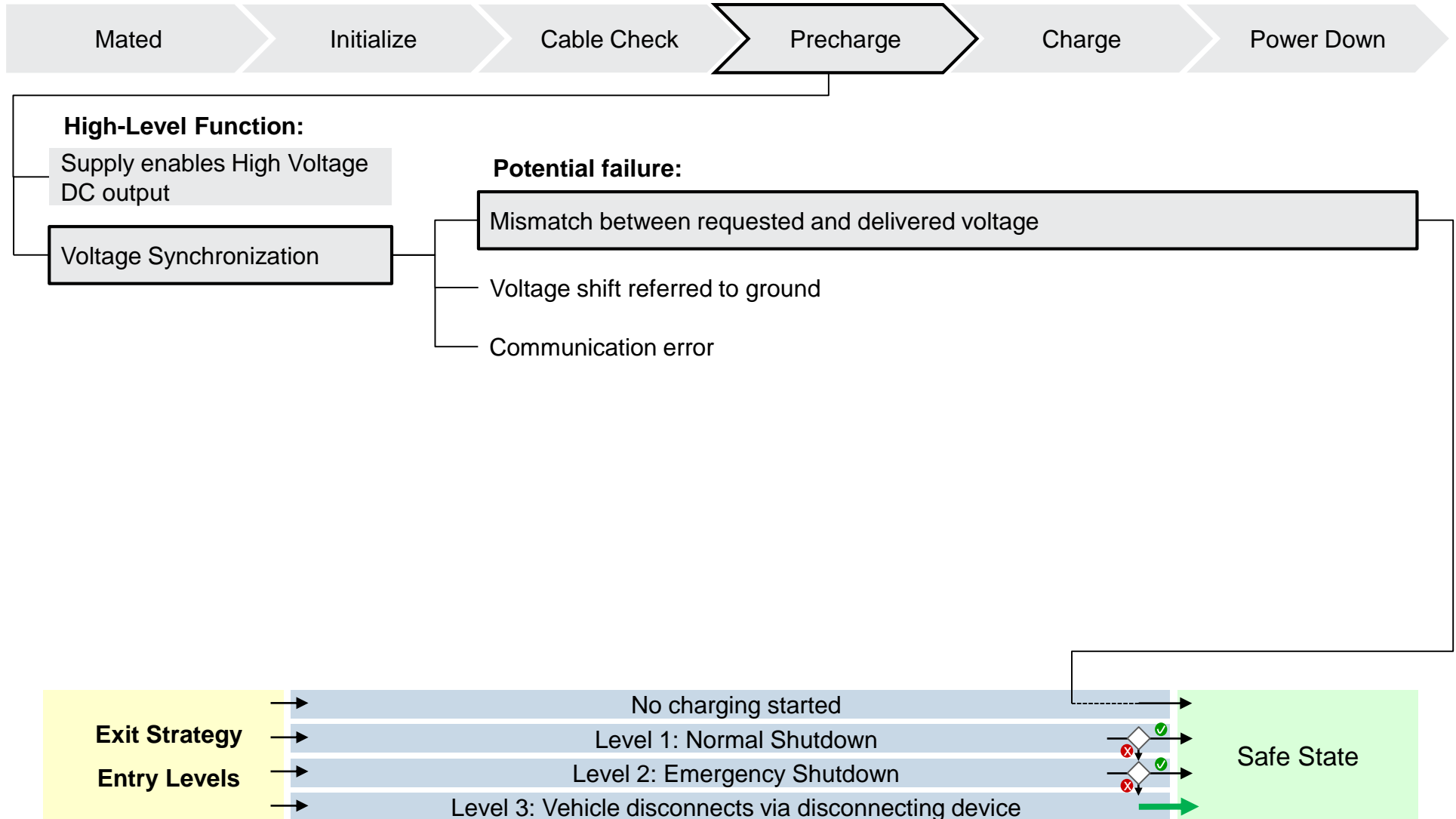

Potential Failure: Supply Control Malfunction: Requested Voltage Not Delivered

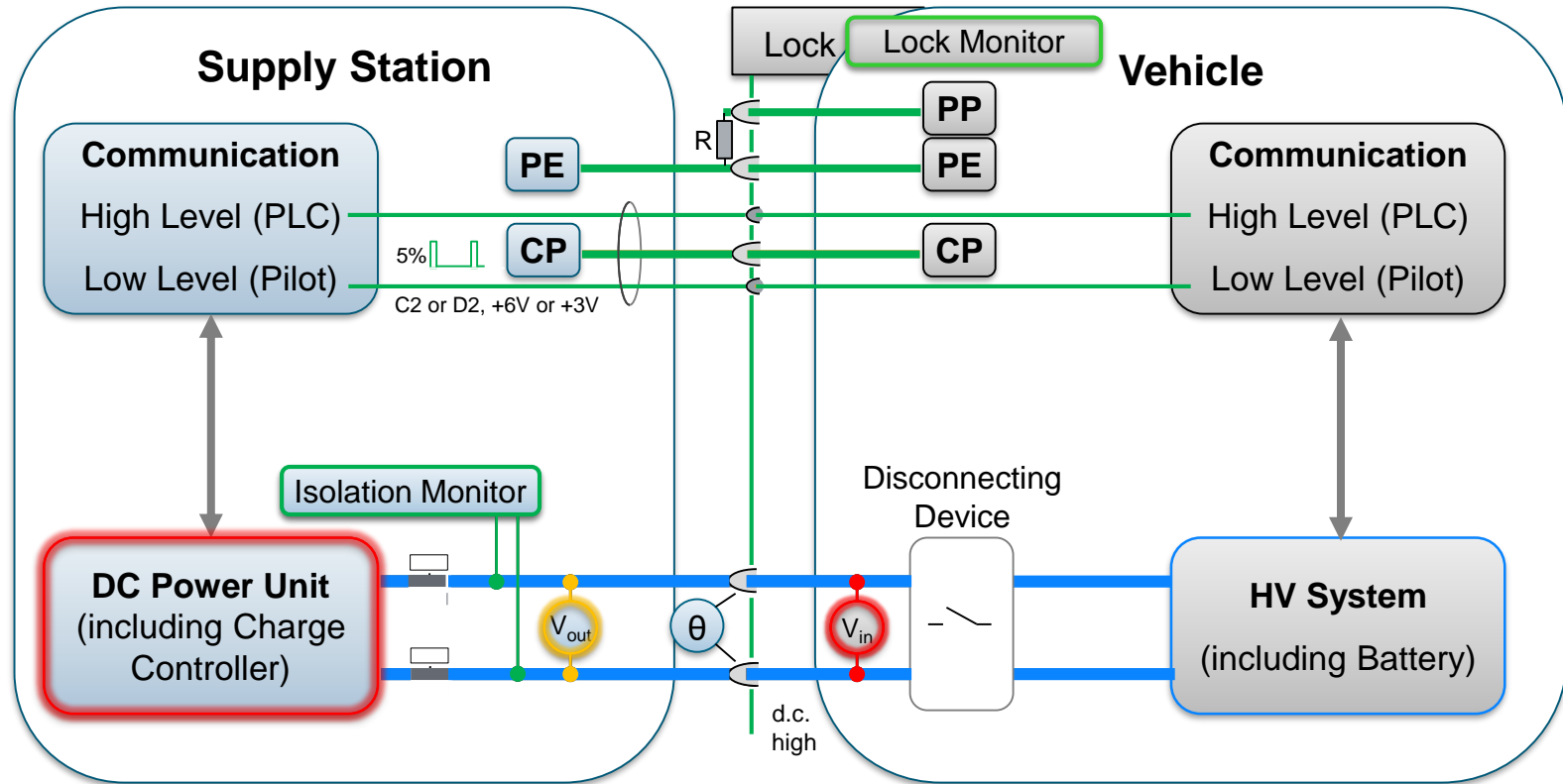

- Potential Effects: Precharge Voltage incorrect. High power inrush current
- Detection: Vehicle input voltage measurement and consistency check with requested supply voltage
- Mitigation: Vehicle disconnecting device still open. No charging started.
- Implemented in ISO/IEC 15118-2 ¹⁾ 8.7.2.2, ISO 17409 5.6.2, ISO 17409, 9.1 last paragraph

¹⁾ In conjunction with ISO/IEC 15118 please note also DIN SPEC 70121.

Sequence Phase: Precharge

Certain failures have been identified for the following phase.
The failure prevention measures/exit strategies will lead to a safe state.

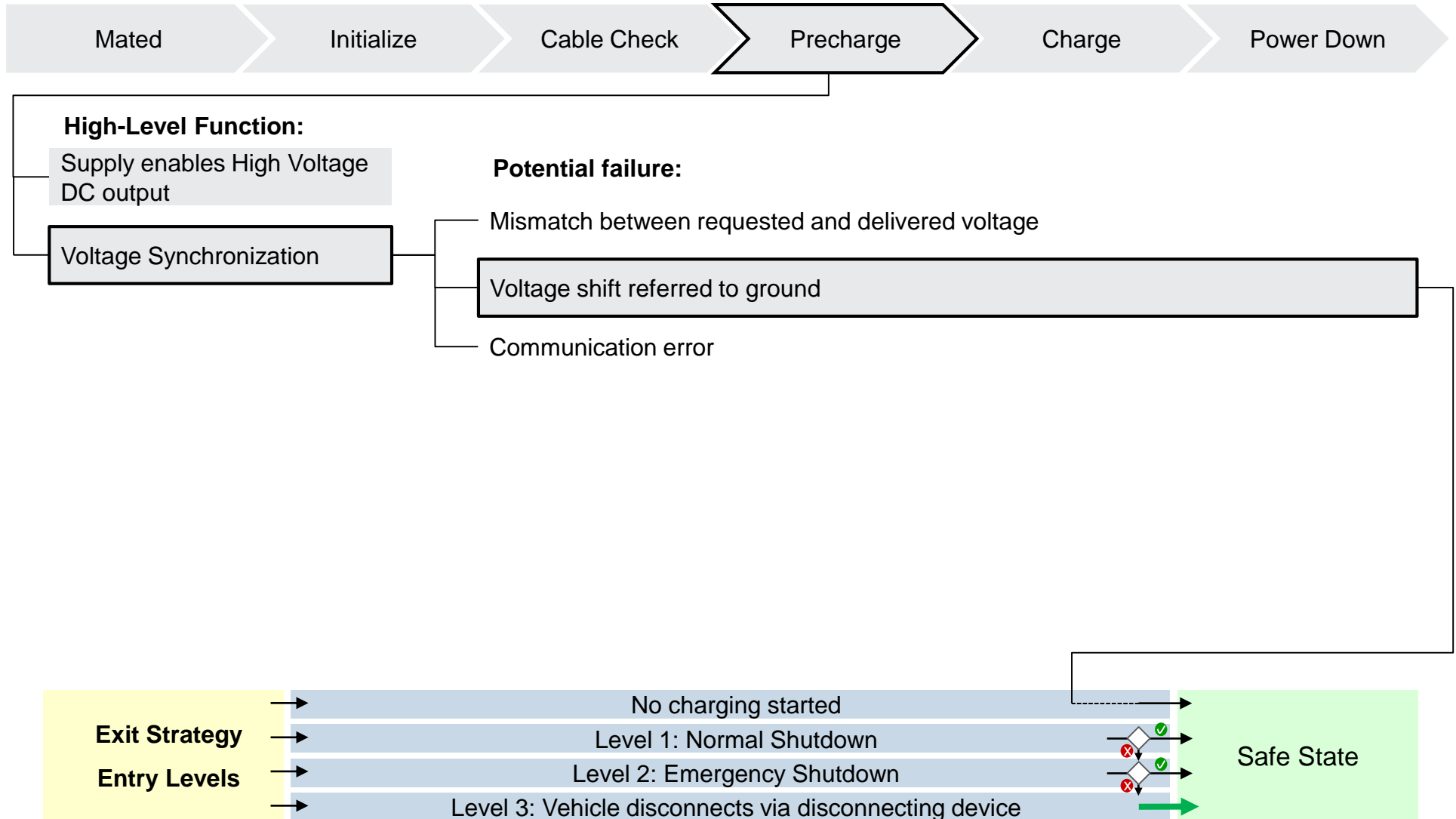

Sequence Phase: Precharge

Certain failures have been identified for the following phase.
The failure prevention measures/exit strategies will lead to a safe state.

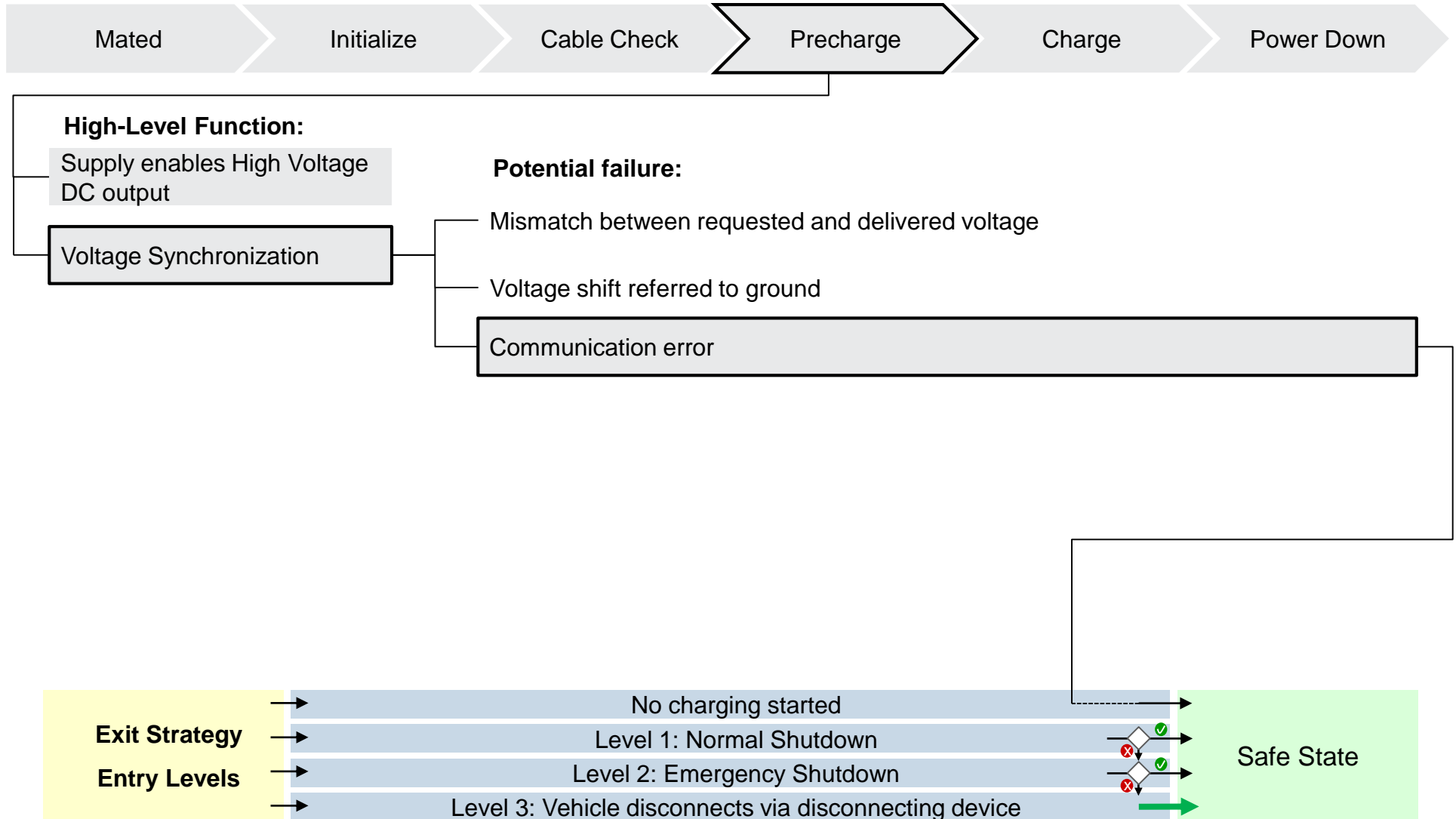

Potential Failure: Communication Error (e.g. manipulation, external attack)

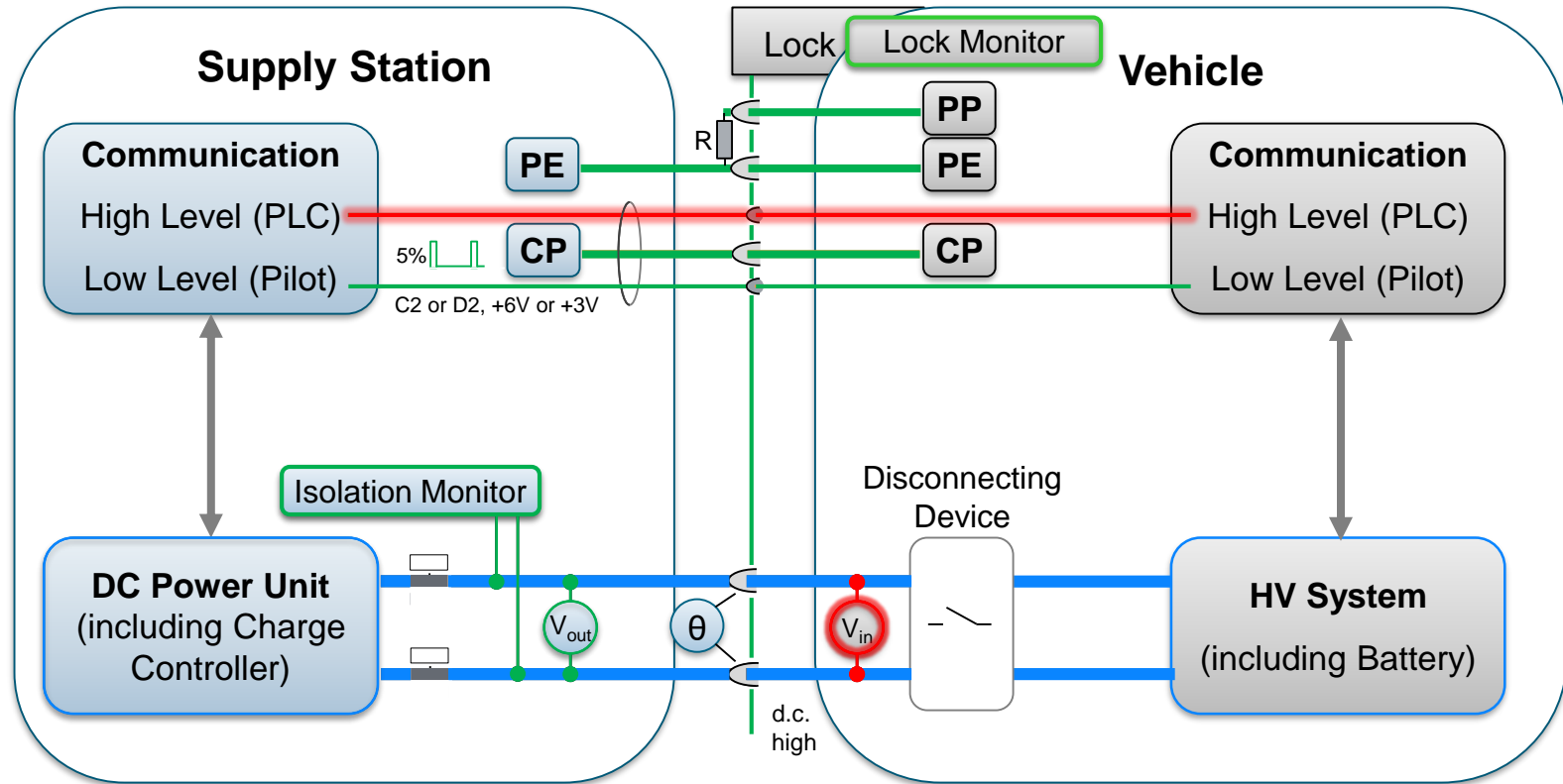

- Potential Effects: Incorrect voltage supplied; Timeout
- Detection: Input voltage measurement and consistency check with requested supply voltage
- Mitigation: Vehicle disconnecting device still open, no charging started
- Standard Ref: ISO/IEC15118-2 ¹⁾, 8.7.2.2, ISO 17409, 9.1 last paragraph

¹⁾ In conjunction with ISO/IEC 15118 please note also DIN SPEC 70121.

Sequence Phase: Charge

Certain failures have been identified for the following phase.
The failure prevention measures/exit strategies will lead to a safe state.

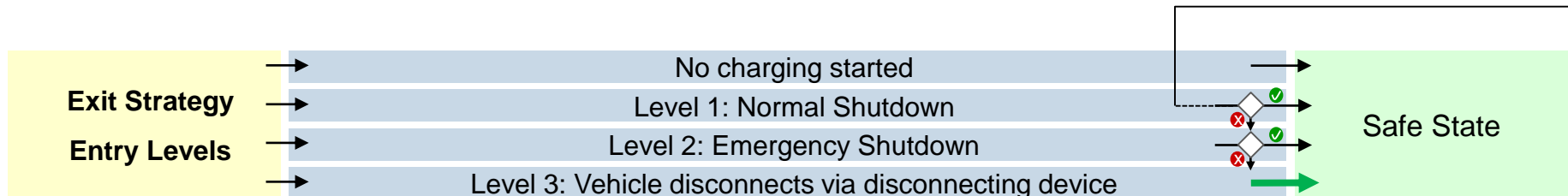
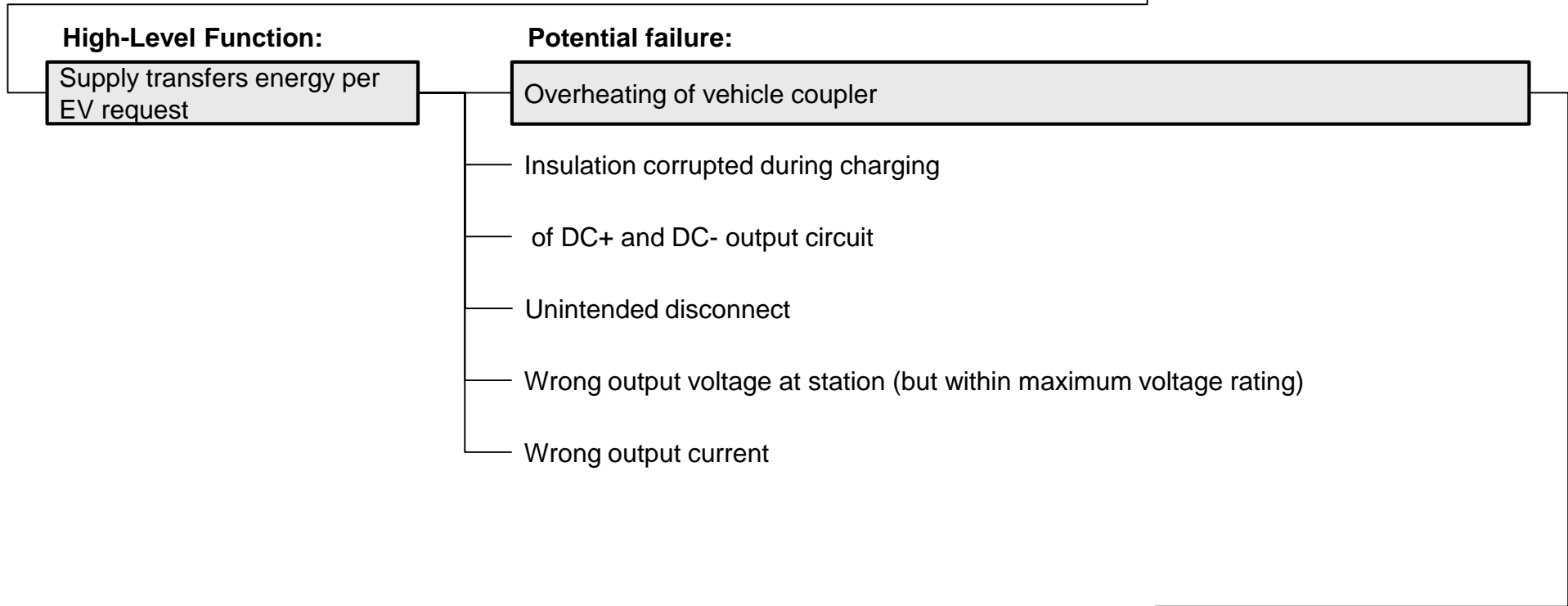

Potential Failure: Overheating of Coupler

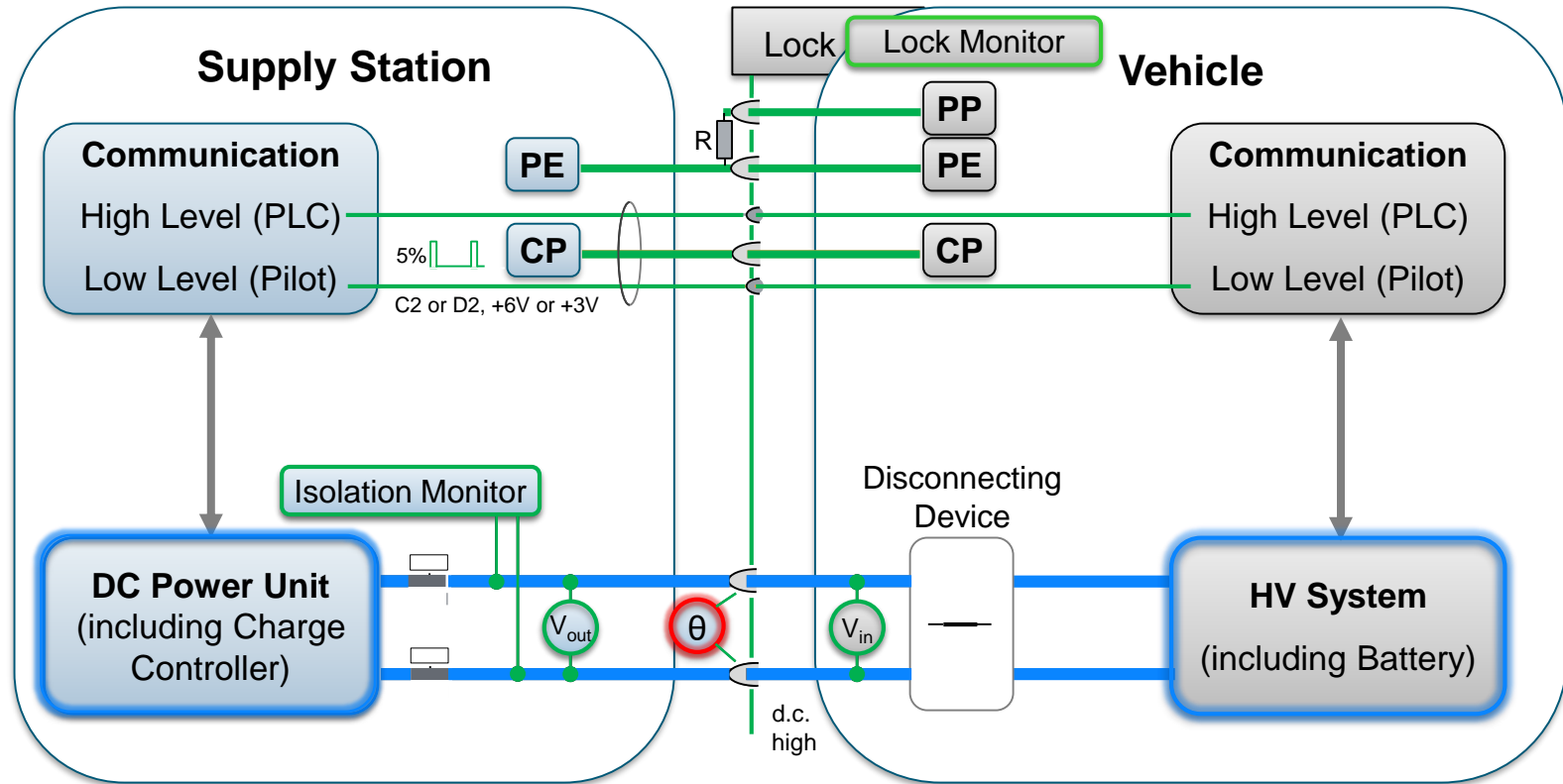

- Potential Effect: Isolation damage of insulation material supporting live parts
- Detection: Temperature monitoring of connector contacts
- Mitigation: Temperature limited by Supply Station. Supply Station will initiate normal shutdown.
- Standard Ref: IEC 61851-23, Annex CC.5.2, IEC 61851-23, CC.4.2 and ISO 17409, 9.6

Sequence Phase: Charge

Certain failures have been identified for the following phase.
The failure prevention measures/exit strategies will lead to a safe state.

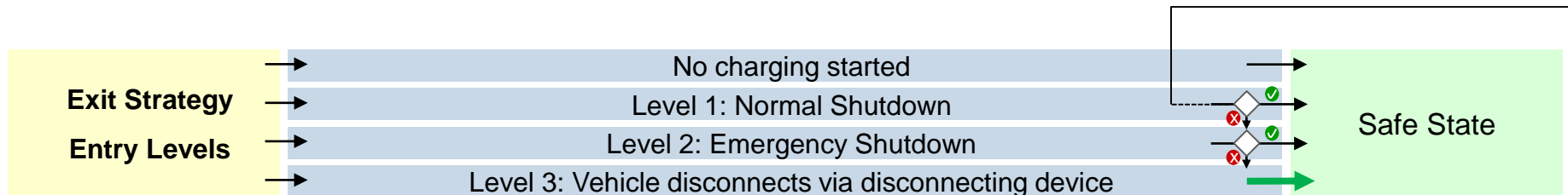
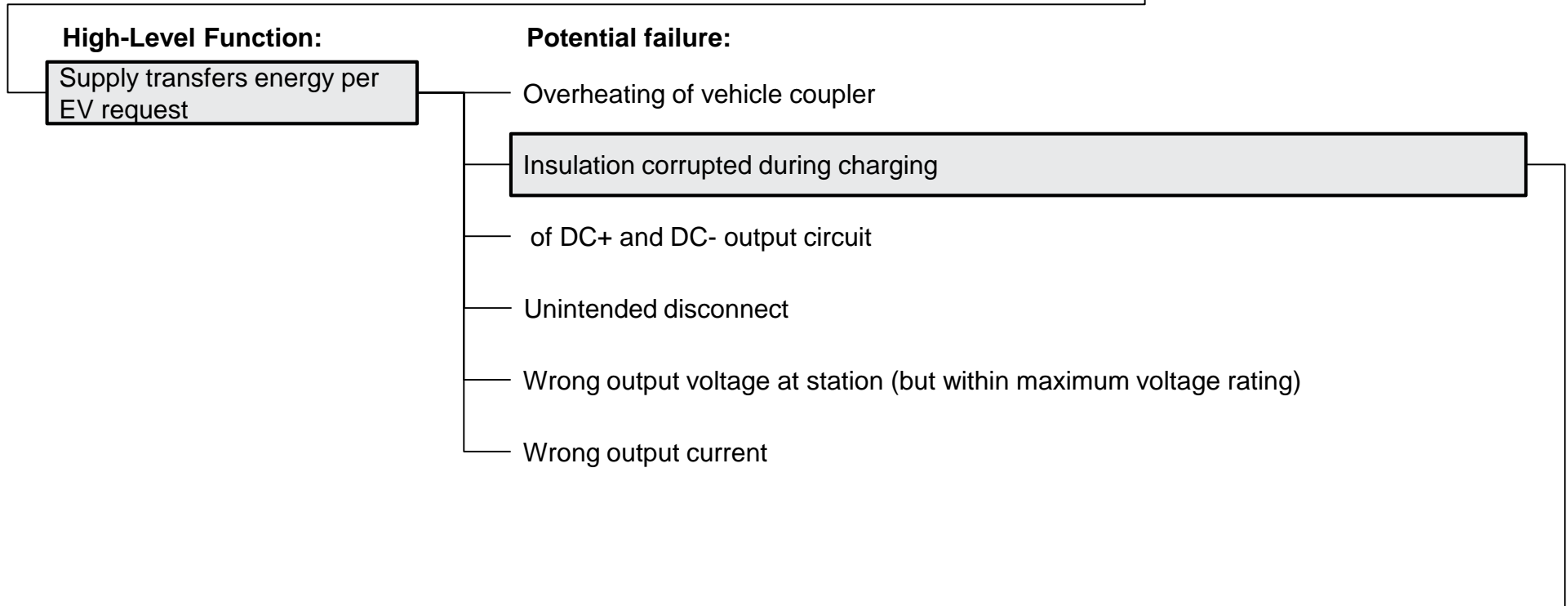

Potential Failure: Insulation Corrupted during Charging

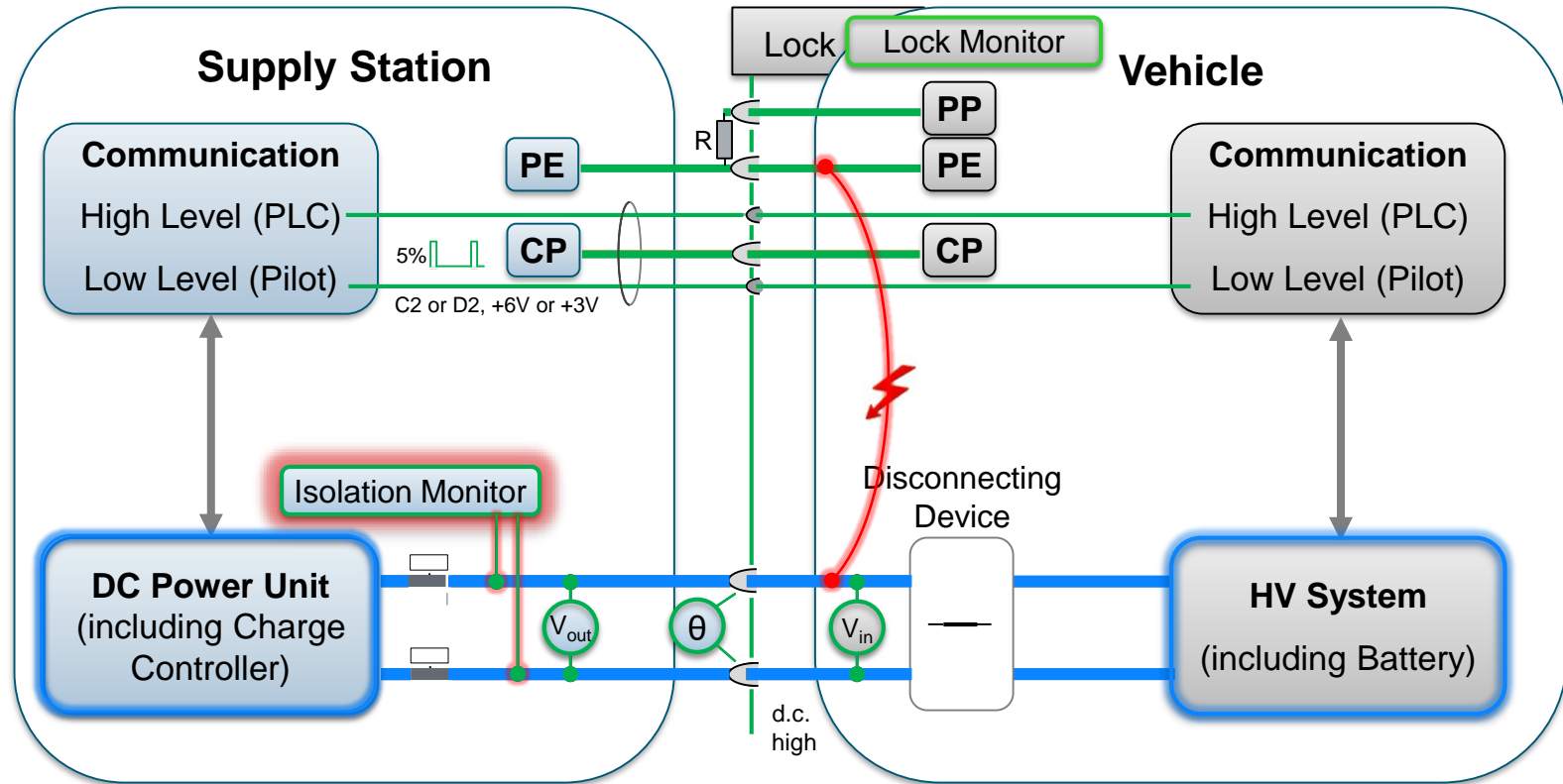

- Potential Effect: Isolation fault
- Detection: Continuous isolation monitoring at station (<100kOhm)
- Mitigation: Fault state of isolation monitor and supply initiated normal shutdown
- Standard Ref: IEC 61851-23, Annex CC.5.1

Sequence Phase: Charge

Certain failures have been identified for the following phase.
The failure prevention measures/exit strategies will lead to a safe state.

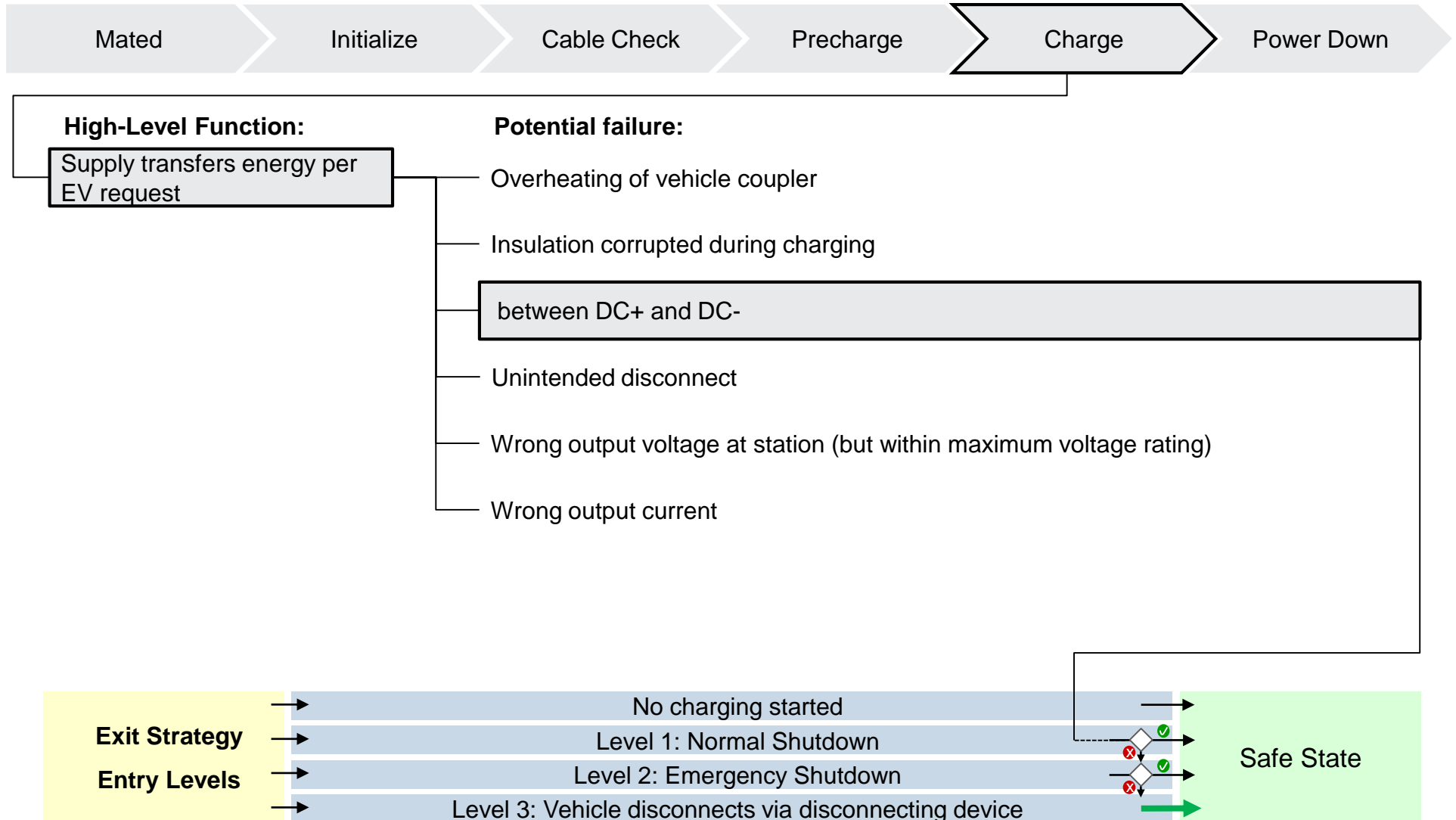

Potential Failure: Between DC+ & DC-

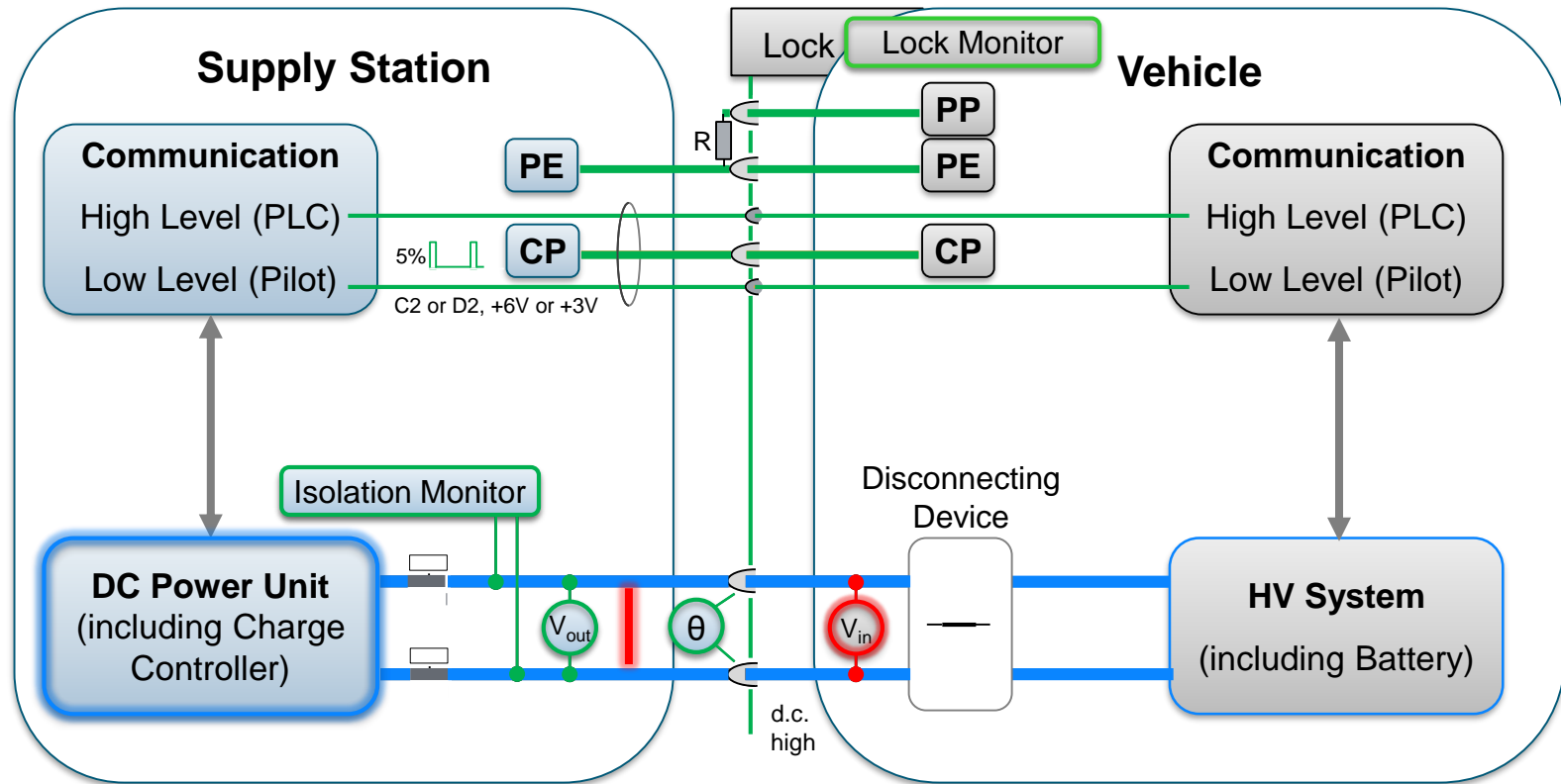

- Potential Effects: Overheating, Arching
- Detection: EV and EVSE voltage measurement recognises low voltage
- Mitigation: Vehicle over-current protection, vehicle initiated normal shutdown
- Standard Ref: ISO 17409 Clause 6.

Sequence Phase: Charge

Certain failures have been identified for the following phase.
The failure prevention measures/exit strategies will lead to a safe state.

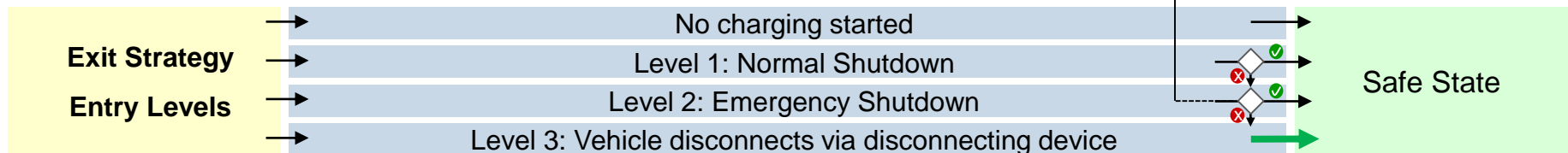
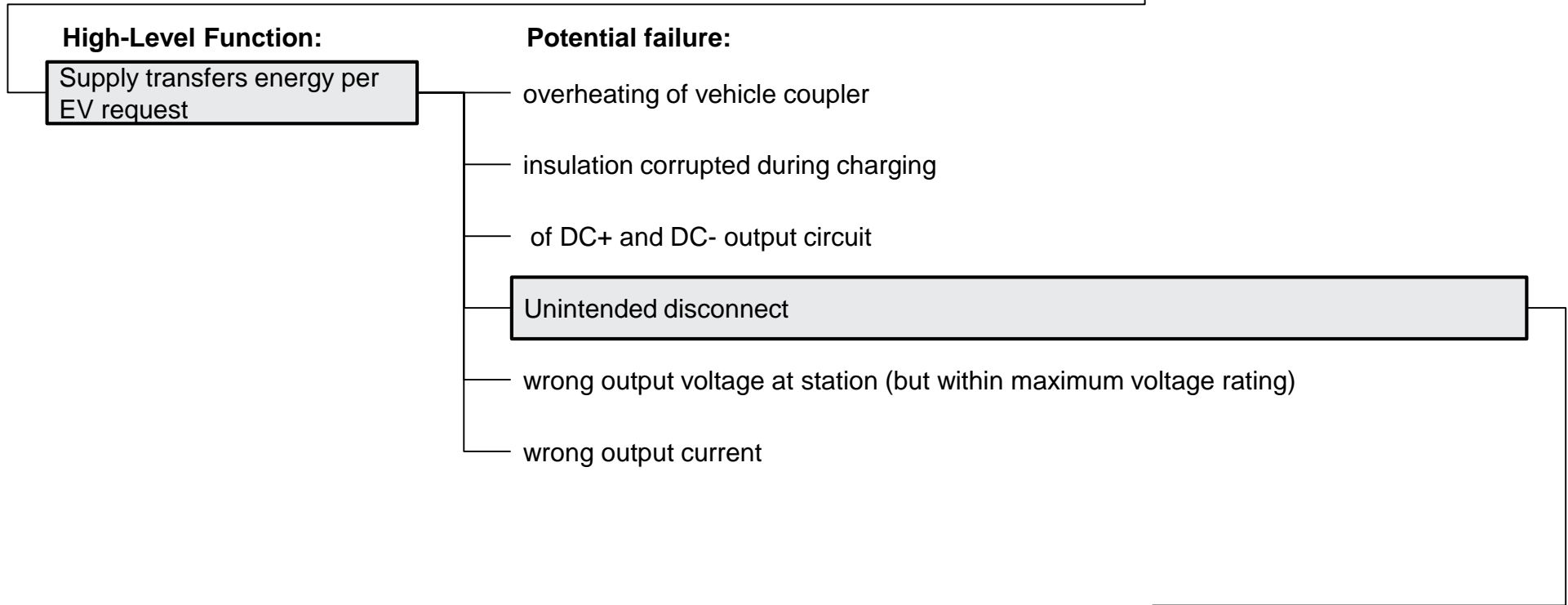

Prevention by design for Unintended Disconnect

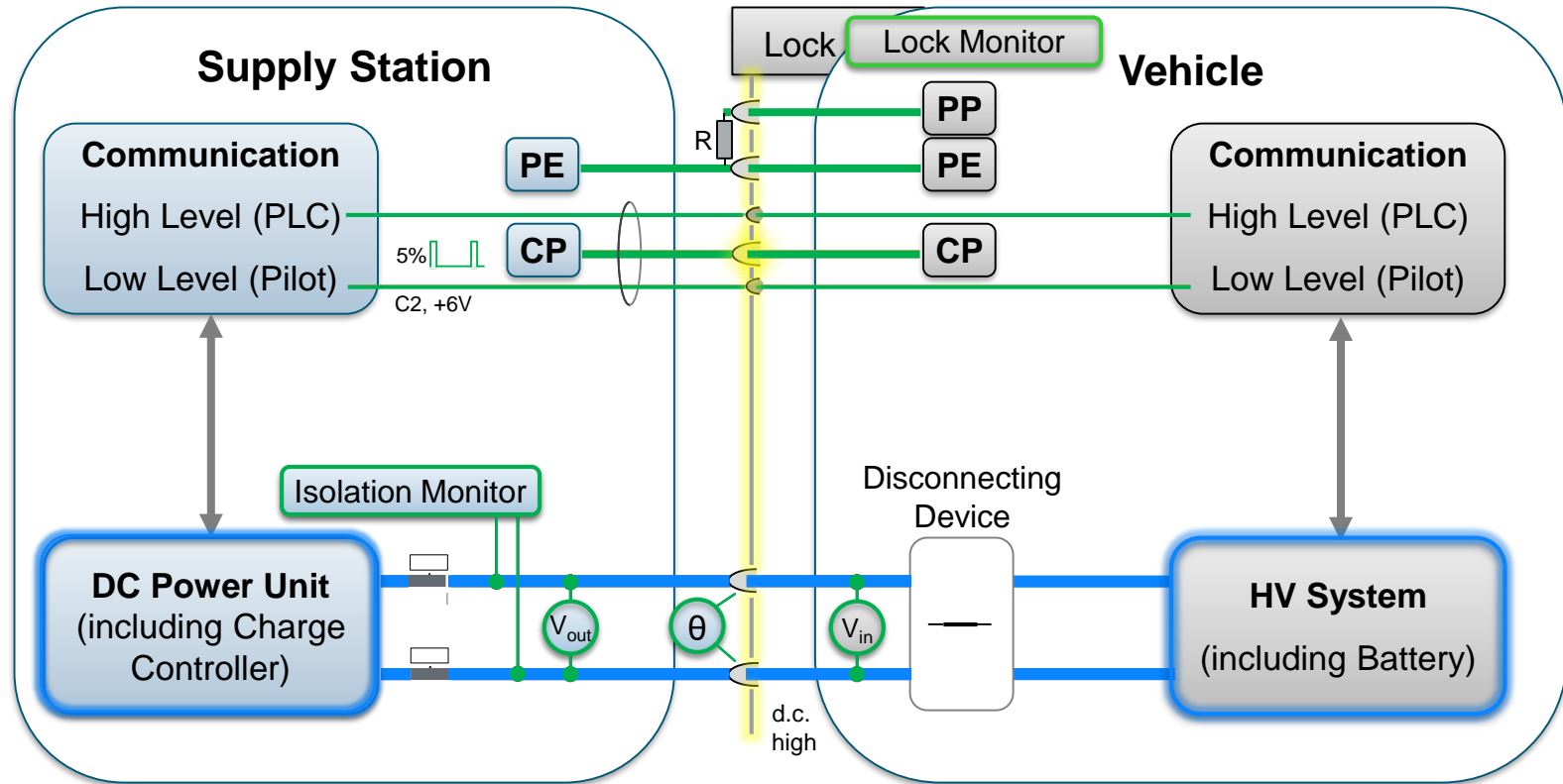

- Potential Effect: Hot disconnect with arc
- Detection: None required
- Mitigation: Locking of connector (752N)
- Standard: IEC 62196-3 26.302, ISO 17409 Clause 9, IEC 61851-23 6.4.3.104

Breaking Capacity according to IEC 61851-23 9.4

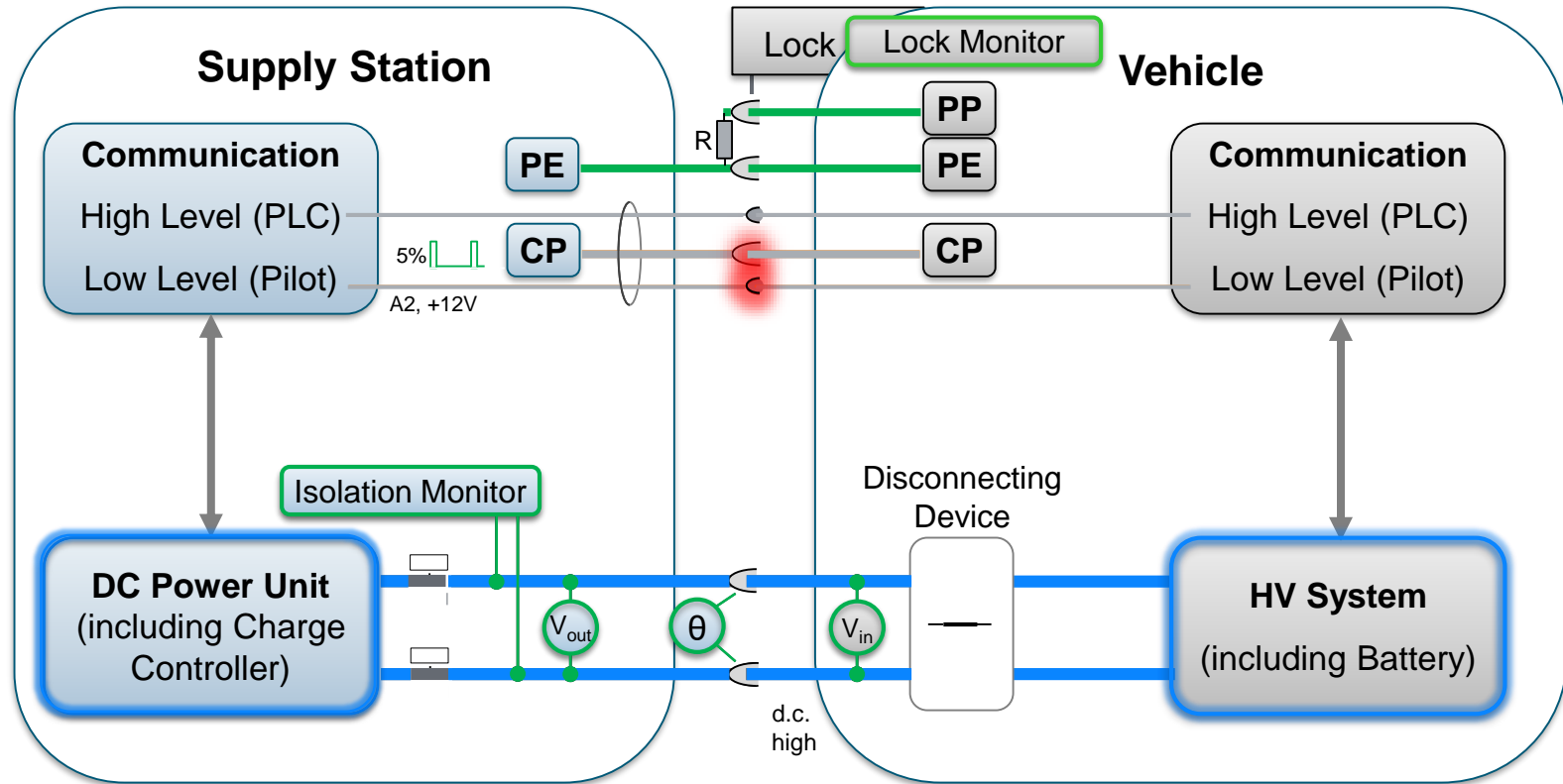

- Potential Effect: Hot disconnect with arc
- Detection: Interlocking – Interruption of CP (state change from C2 -> A2)
- Mitigation: CP lost shutdown (<5A within 30ms, <60V within 100ms)
- Standard Ref: IEC 61851-23 9.4, IEC 61851-23 Annex CC.5.4

Sequence Phase: Charge

Certain failures have been identified for the following phase.
The failure prevention measures/exit strategies will lead to a safe state.

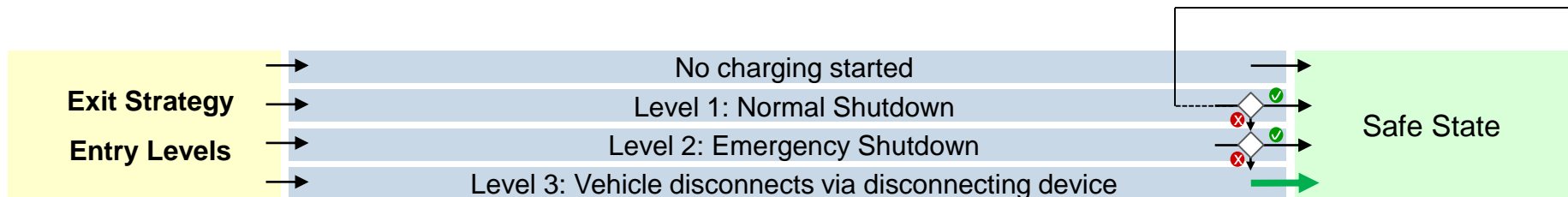
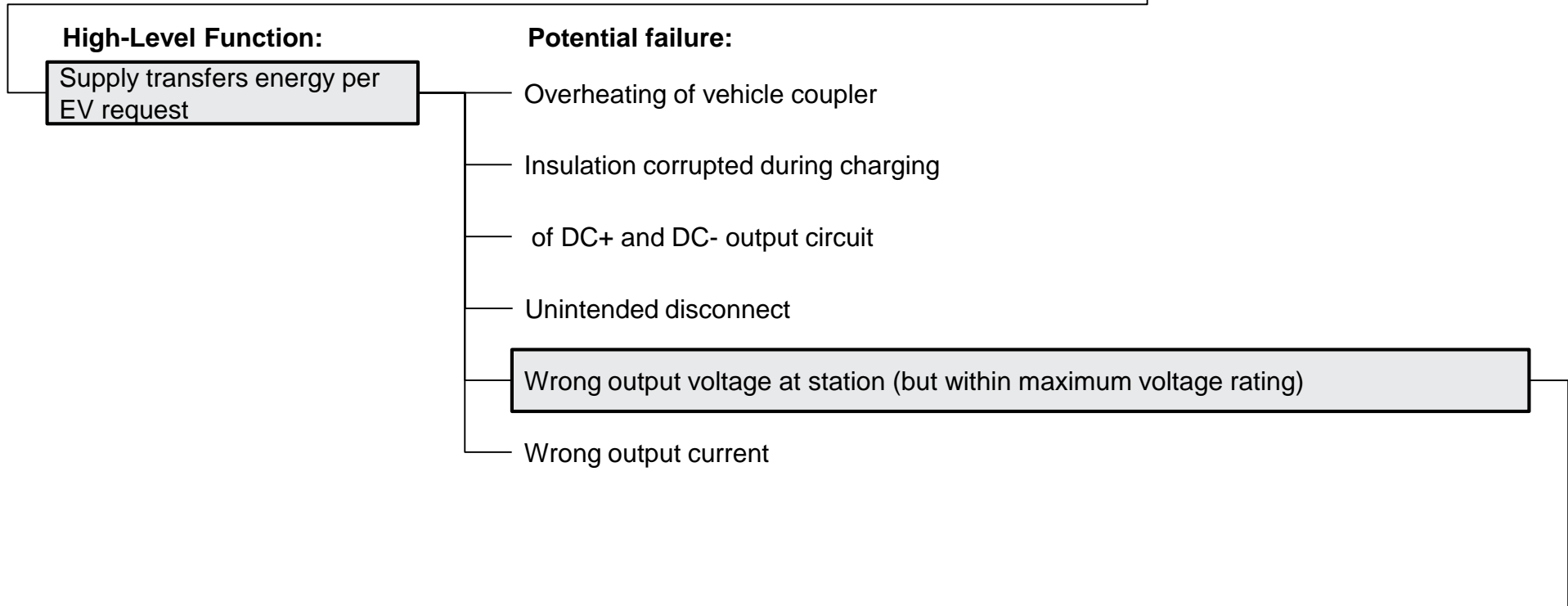

Potential Failure: Wrong Output Voltage at Station (Within Maximum Voltage Rating)

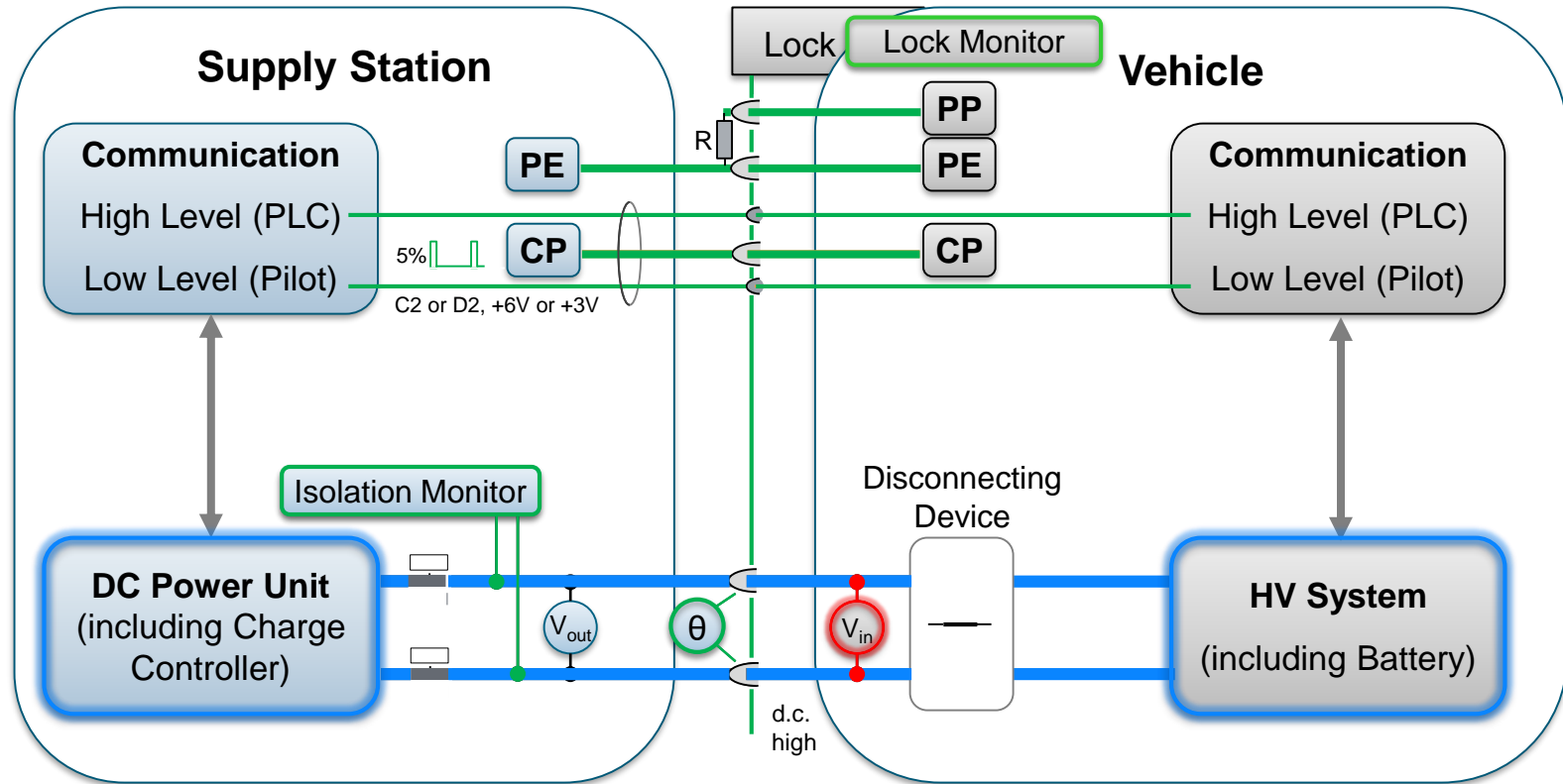

- Potential Effect: Higher voltage at output than requested or lower voltage (may lead to reverse power flow)
- Detection: Voltage measurement within EV and consistency check with requested voltage
- Mitigation: 1. Voltage change request, if no reaction: 2. Normal shutdown
- Standard Ref: ISO 17409, 9.4

Sequence Phase: Charge

Certain failures have been identified for the following phase.
The failure prevention measures/exit strategies will lead to a safe state.

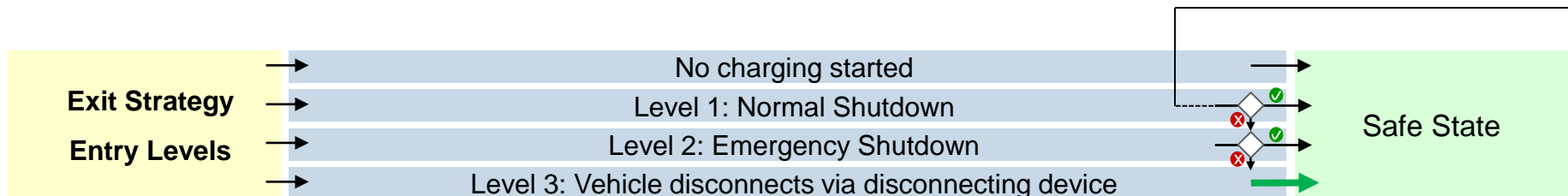
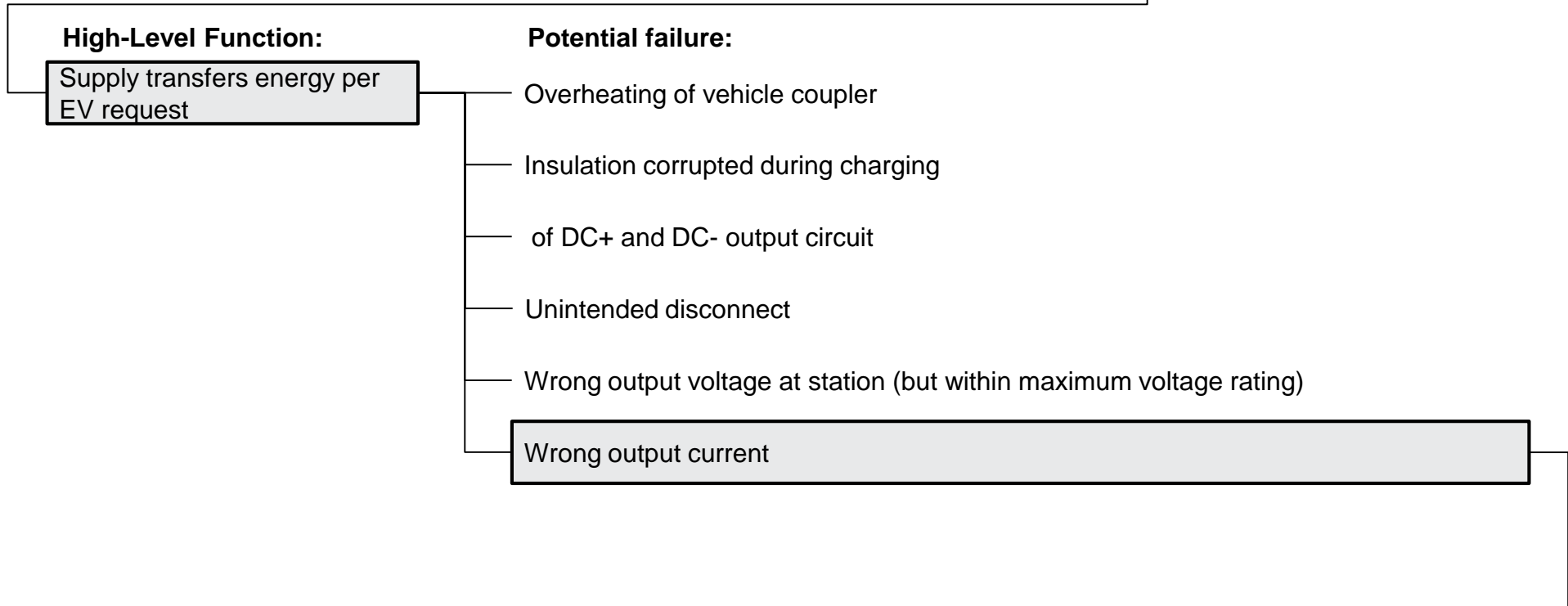

Potential Failure: Wrong Output Current at Station

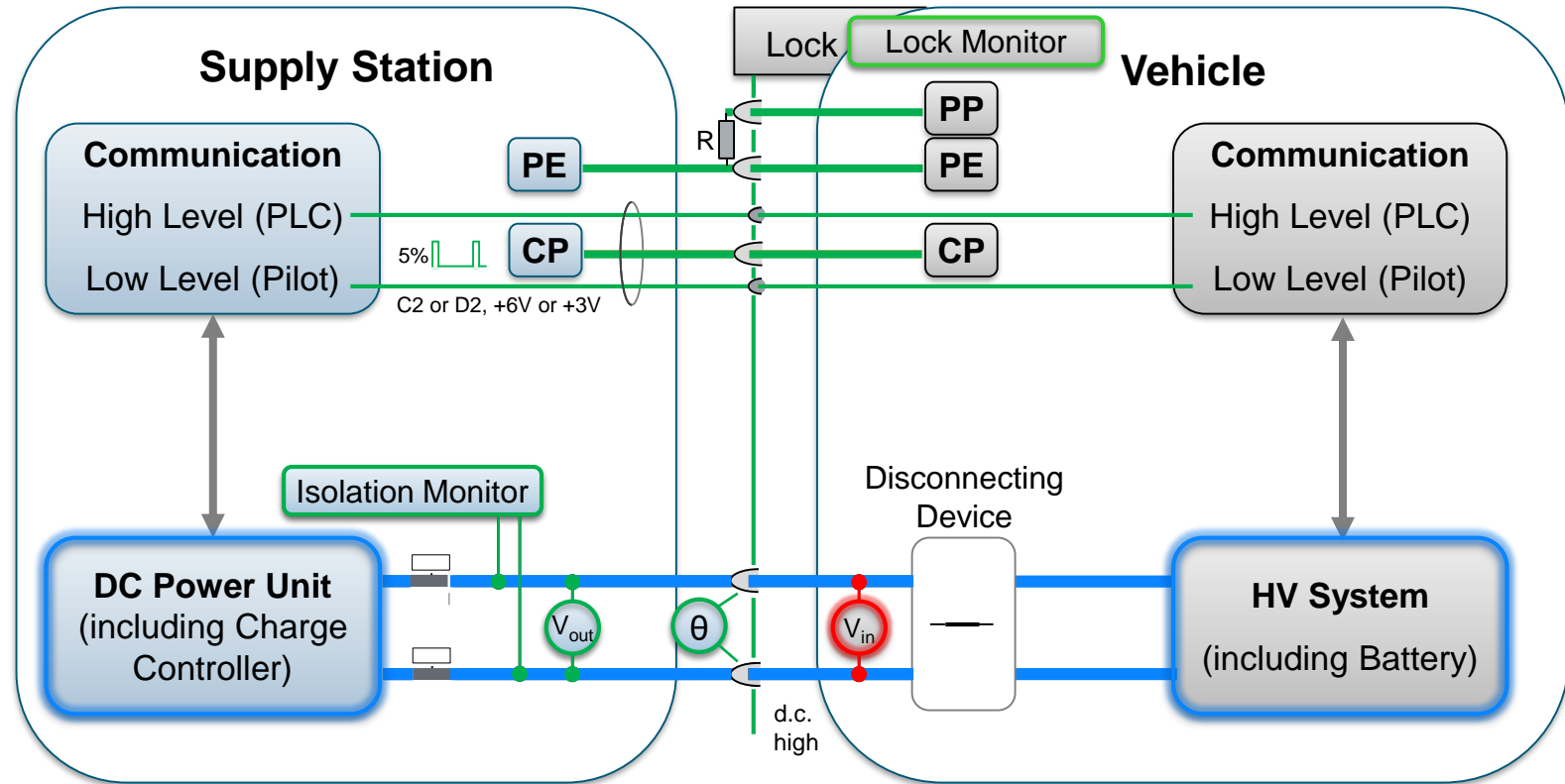

- Potential Effect: Overcurrent, overheating of components in vehicle due to high current
- Detection: Current measurement within EV
- Mitigation: Entry point Safe State: Vehicle initiated normal shutdown, vehicle fuse within HV system breaks
- Standard Ref: ISO17409, Third paragraph

Sequence Phase: Power Down

Certain failures have been identified for the following phase.
The failure prevention measures/exit strategies will lead to a safe state.

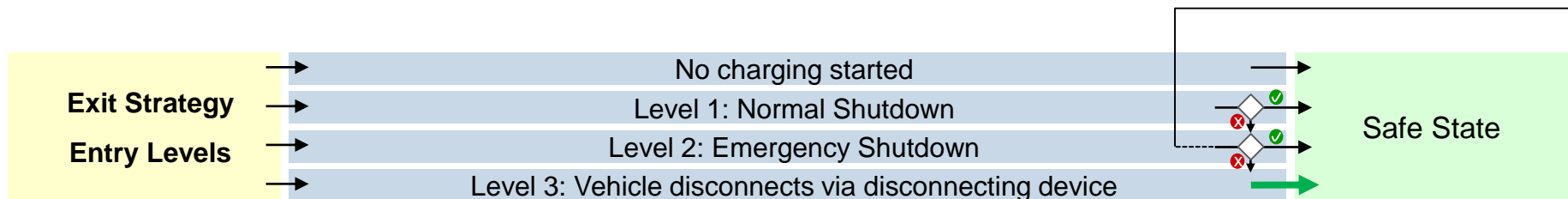
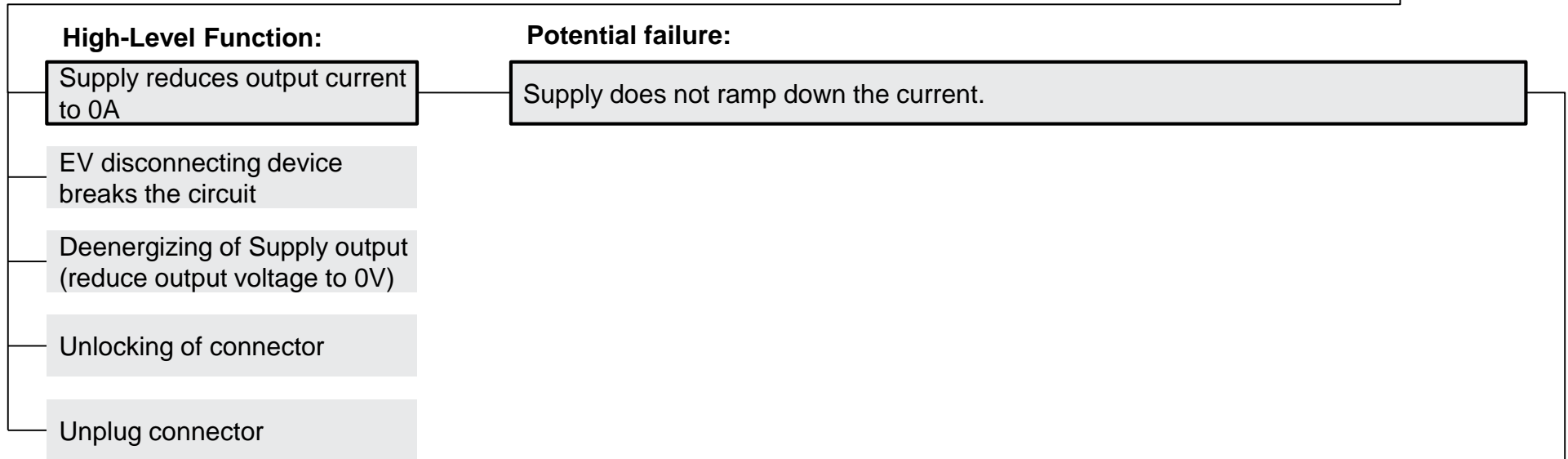

Potential Failure: Supply does not Ramp Down Voltage

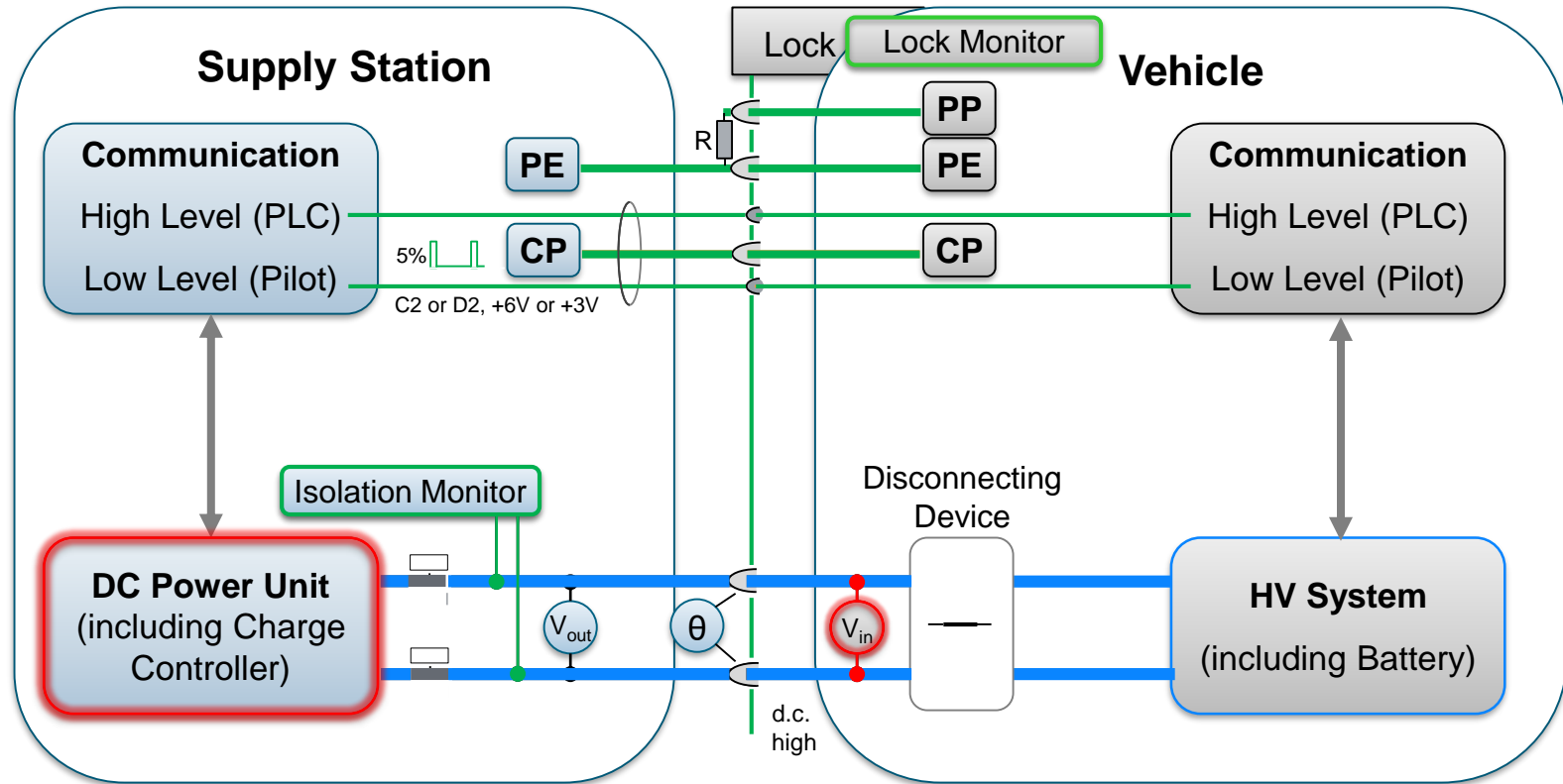

- Potential Effects: Overvoltage, overcurrent
- Detection: Vehicle input voltage measurement, current derived
- Mitigation: Vehicle disconnecting device opens, Vehicle initiated emergency shutdown
- Standard Ref: ISO/IEC 15118-2 ¹⁾, 8.7.2.2, ISO17409, third paragraph

¹⁾ In conjunction with ISO/IEC 15118 please note also DIN SPEC 70121.

Sequence Phase: Charge

There are no failures for the marked High Level Function.



High-Level Function:

Supply reduces output current to 0A

EV disconnecting device breaks the circuit

Deenergizing of Supply output (reduce output voltage to 0V)

Unlocking of connector

Unplug connector

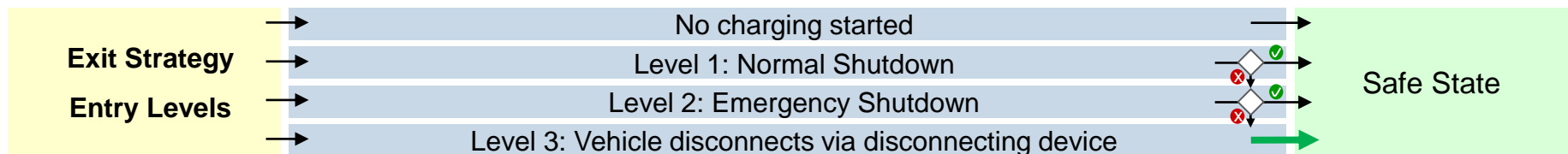

Sequence Phase: Charge

Certain failures have been identified for the following phase.
The failure prevention measures/exit strategies will lead to a safe state.

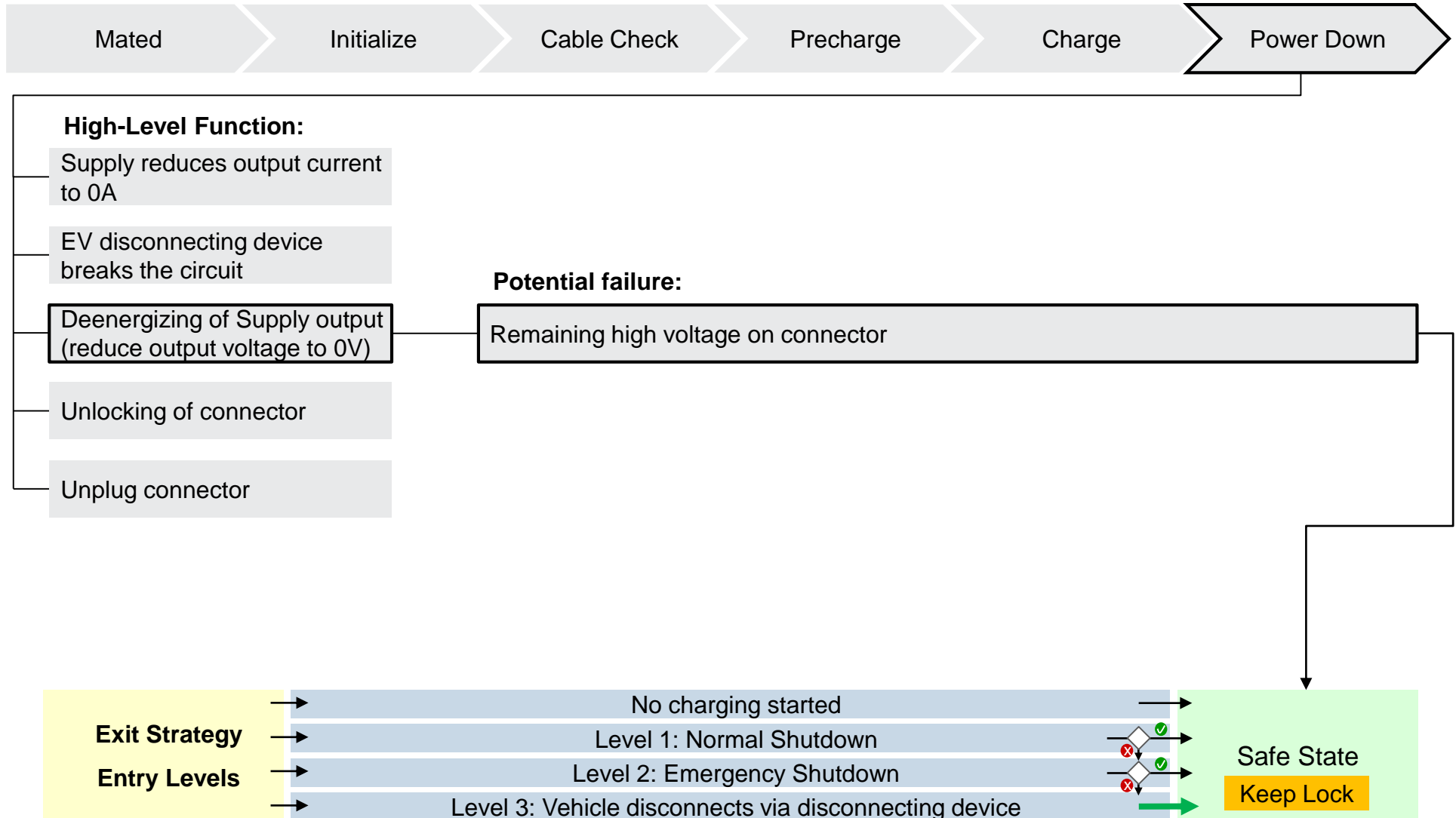

Potential Failure: Supply does not De-Energize (Remaining high voltage on connector)

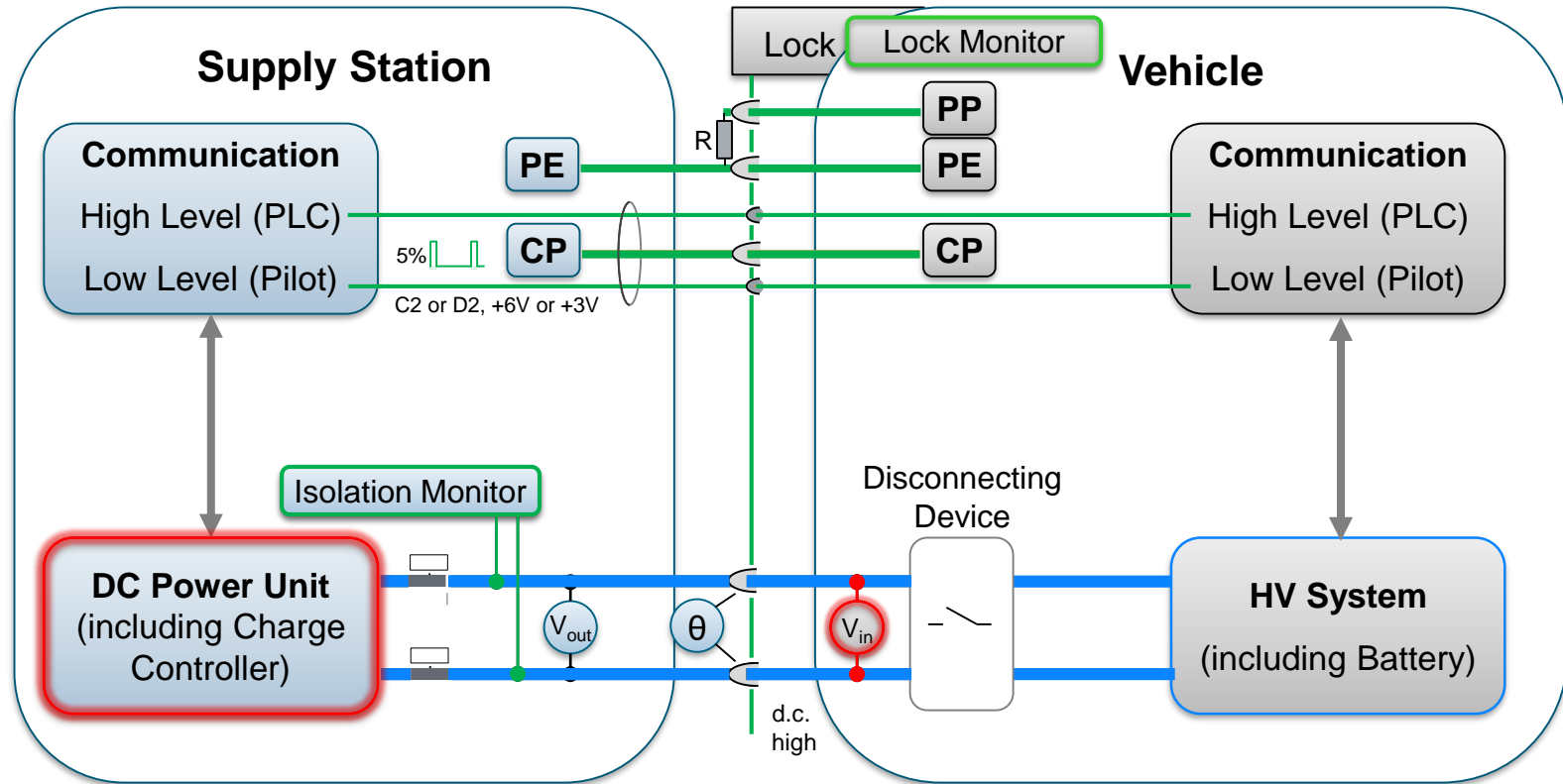

- Potential Effects: Overvoltage
- Detection: Vehicle input voltage measurement
- Mitigation: Sequence stopped, next function cannot be entered (unlocking), keep lock
- Standard Ref: ISO/IEC 15118-2 ¹⁾, 8.7.2.2, ISO 17409, 5.5.3

¹⁾ In conjunction with ISO/IEC 15118 please note also DIN SPEC 70121.

Sequence Phase: Charge

There are no failures for the marked High Level Function.

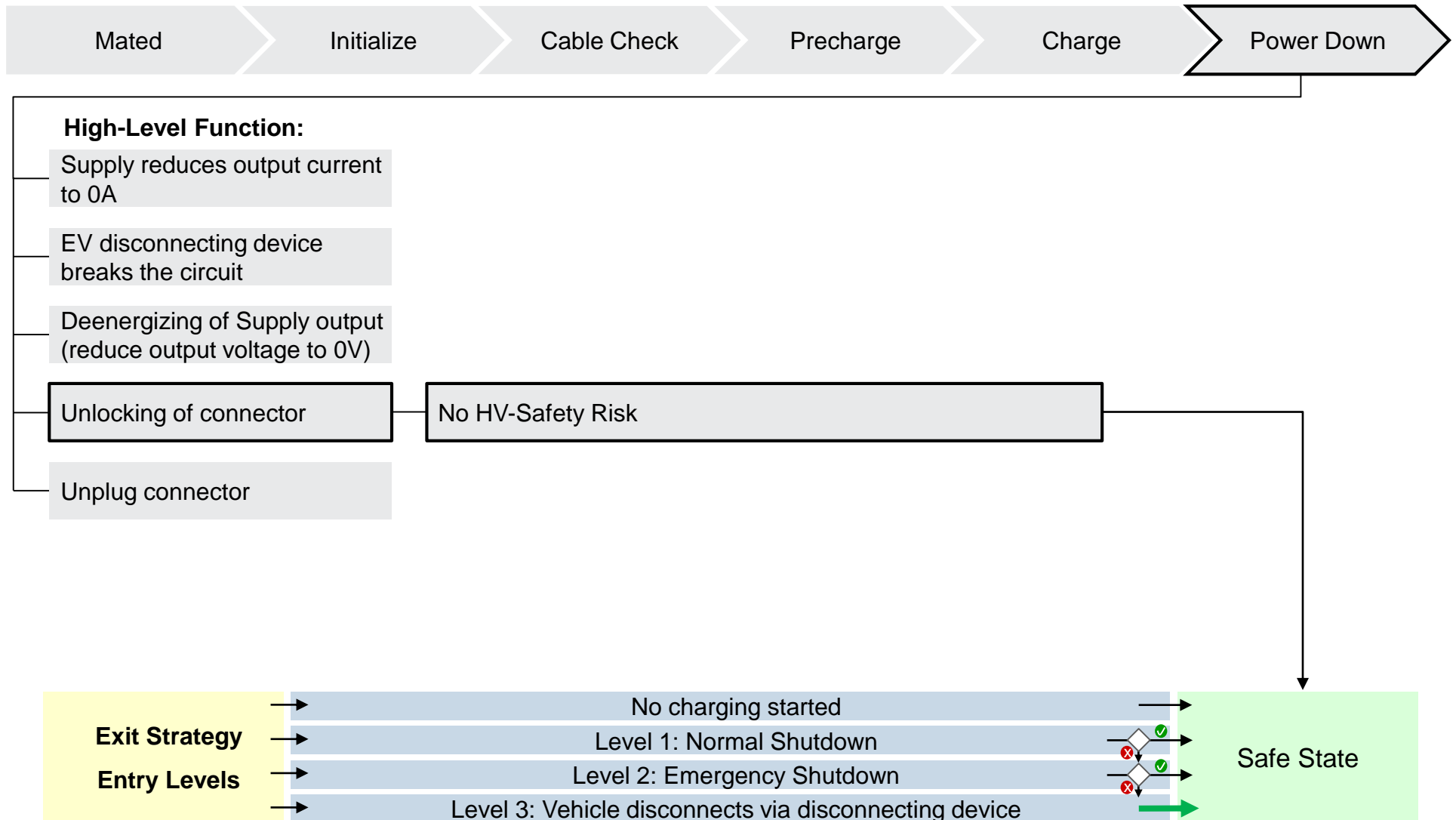

Sequence Phase: Charge

Certain failures have been identified for the following phase.
The failure prevention measures/exit strategies will lead to a safe state.

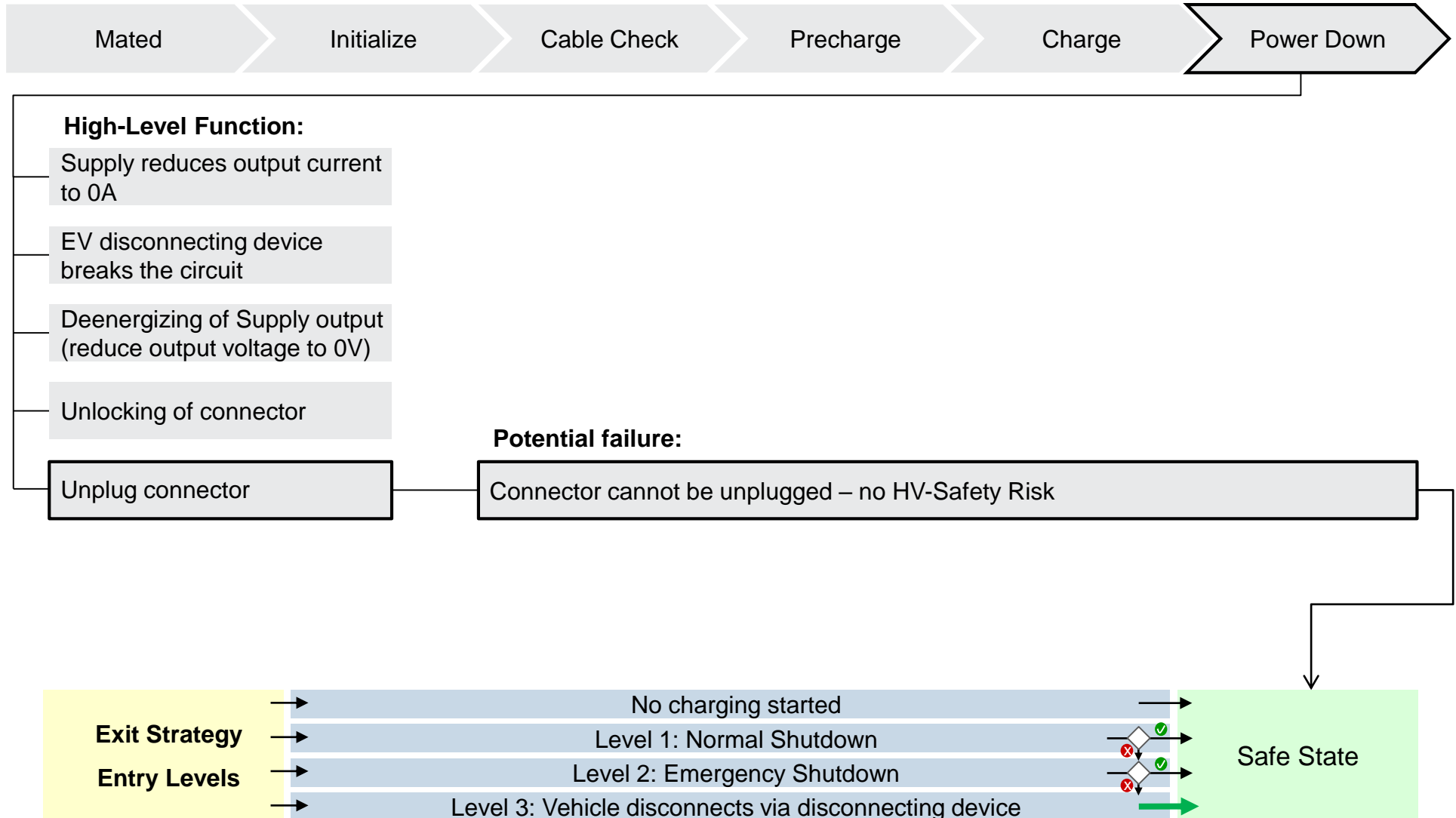

Agenda

1 Introduction

2 Illustration of Supply Sequence

3 Illustration of Pulse Width Modulation

4 Illustration of SLAC Sequence

5 Illustration of High Level Communication

6 Potential failures within charging sequence (DINSpec 70121 implemented)

7 Safety Concept for Potential Failures within Supply Sequence

8 Additional key points for EVSE's

9 Relevant Standards

General information for EVSE's

Advice to implement a waiting time for authentication

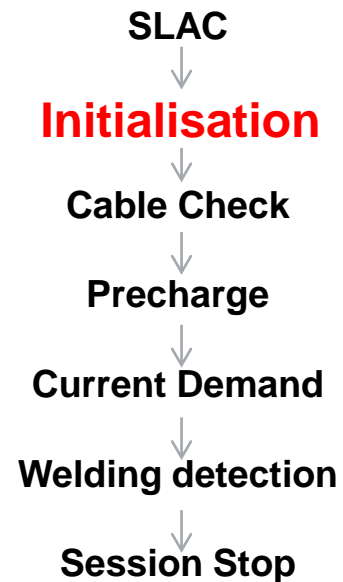

There can be two different ways for the customer to start the charging process:

I	II
1. Authenticate	1. Plug-in connector
2. Press „start“ button	2. Authenticate
3. Plug-in connector	3. Press „start“ button

For both sequences (especially for sequence II) it will be important to implement waitingtime in the sequence for the customer to press the start button.

For this time, please use a loop in the ContractAuthentication message. A waiting time for the customer at this period could be as long as 2 minutes at the EVSE side. So the customer can press the „start“-button at any time until ContractAuthentication and will see a succesfull charging.

General information for EVSE's

Additional key points I

- Protection against environmental condition for the repository of the CCS Connector shall be considered.
- IP-protection of cabinet/housing of charging station shall be considered.
- All PE-lines shall be connected to one ground terminal to prevent different ground potentials between different boards.
- Documentation with reference to serial number of charging station shall include information on implemented software version.
- Requirement to send a response code like „failed“ if messages were send at the wrong time shall be implemented according to DIN SPEC 70121:2014-12, [V2G-DC-666].

General information for EVSE's

Additional key points II

- CM_SLAC_MATCH.cnf from EVSE shall be send as unicast message
- Pilot voltage shall be in state B1 after coming from state B2, until connector is plugged out. Oscillator shall not be started again.

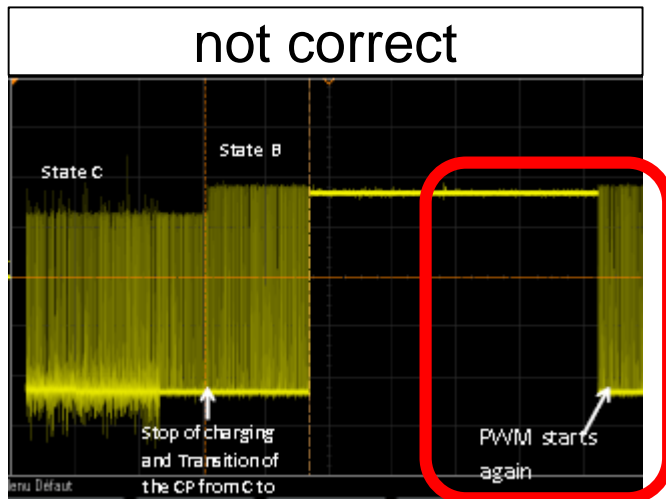

Agenda

1 Introduction

2 Illustration of Supply Sequence

3 Illustration of Pulse Width Modulation

4 Illustration of SLAC Sequence

5 Illustration of High Level Communication

6 Potential failures within charging sequence (DINSpec 70121 implemented)

7 Safety Concept for Potential Failures within Supply Sequence

8 Additional key points for EVSE's

9 Relevant Standards

Standards

The overview of standards shows all the necessary standards which has to be applied for build up a d.c. fast-charging system. All listed manufacturers are active in the field of DC fast-charging infrastructure.

Description

- Based on the standards a complete and organized list clarifies the content of each standard. Available information are associated document number, title, content and optionally some comments.
- The following overview of international and legal standards contains all mandatory and optional requirements. The following fields are taken into account:
 - Connector,
 - Communication,
 - Charging Topology,
 - General Standards
- The following overview of suppliers is an extract and shows some major companies

Disclaimer

Only public available Standards and Specification published by ISO/IEC and the relevant national Standard Bodies have to be used for product development.

The content of this Design Guide is not binding nor can be exclusively used as basis for product development.

As some standards for the Combined Charging System are not finalized yet (status IS), the relevant standards for the Implementation of the Combined Charging System is organized by the Combined Charging System Specification.

General Standards/Description – Functions of the fast charging station

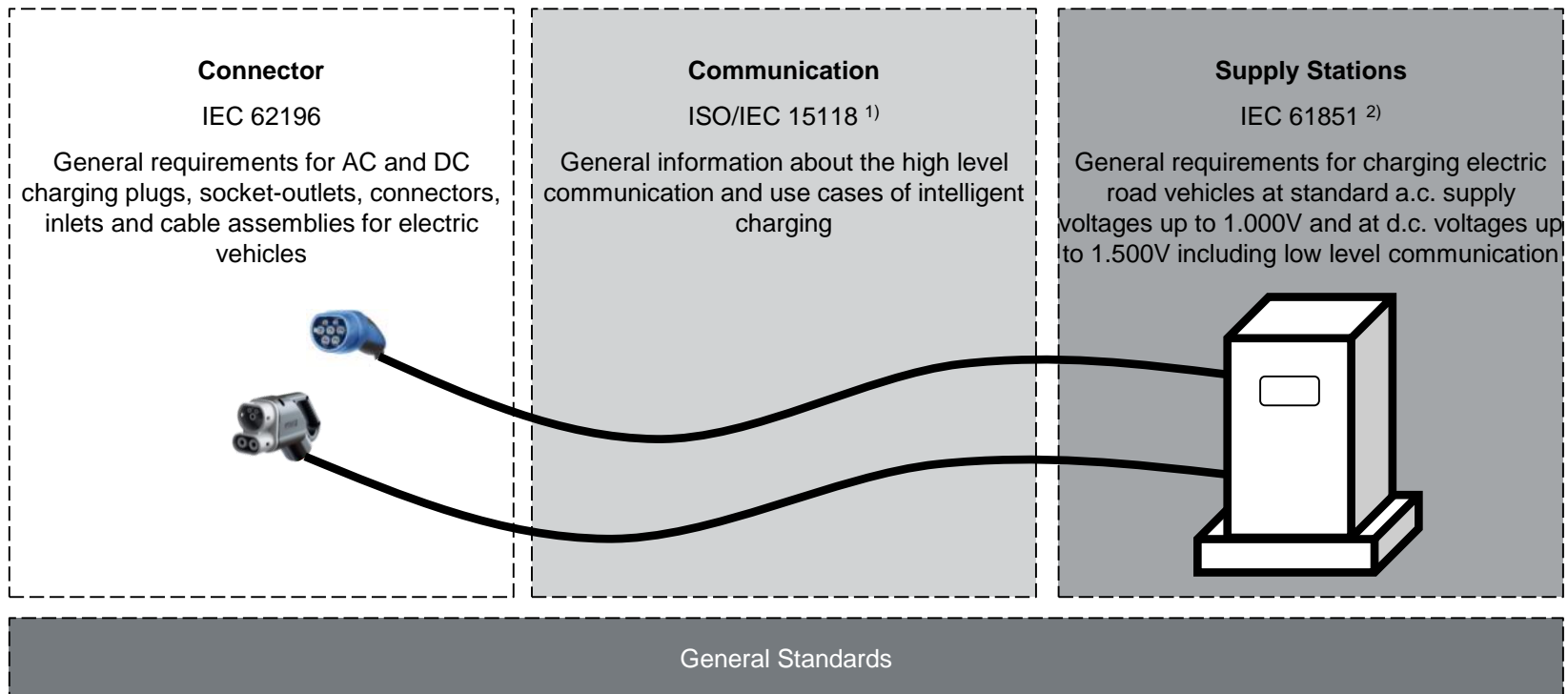

¹⁾ In conjunction with ISO/IEC 15118 please note also DIN SPEC 70121.

²⁾ Please note that IEC 61851-21 as part of IEC 61851 will be replaced by ISO 17409 in the near future.

Under review and may be shifted to the CCS umbrella document

Connector Standards

Document Number	Title	Content	Comments
IEC 62196-1	Part 1: General requirements for Plugs, socket-outlets, vehicle connectors and vehicle inlets - Conductive charging of electric vehicles	General requirements for AC and DC charging with rated operating voltage not exceeding: <ul style="list-style-type: none"> • 690V a.c., 50–60 Hz, at a rated current not exceeding 250A; • 600V d.c., at a rated current not exceeding 400A • Accessories and cable assemblies are to be used in an ambient temperature of between –30 °C and +50 °C 	
IEC 62196-2	Part 2: Dimensional compatibility and interchangeability requirements for a.c. Pin and contact-tube accessories	Requirements contains categorizations on plug types to be used in the AC charging process: <ul style="list-style-type: none"> • Type 1 - single phase vehicle coupler • Type 2 - single and three phase vehicle coupler • Type 3 - single and three phase vehicle coupler with shutters 	<ul style="list-style-type: none"> • Use same PVM Signal (Control Pilot and Protective Earth)
IEC 62196-3	Part 3: Dimensional interchangeability requirements for pin & contact-tube coupler, rated operating voltage & current up to 1.000V d.c., 400A for dedicated d.c. charging.	Specifications on High Power DC couplers (max. 1.000V DC / 400A plugs): <ul style="list-style-type: none"> • Combo 1 and 2 (850V, 200A DC) • Japan CHAdeMO Type 1 (600V, 200A DC) • China DC Type 2 (750V, 250A DC) 	<ul style="list-style-type: none"> • Use same PVM Signal (Control Pilot and Protective Earth)
NAR pendant:			
SAE J1772	Electric vehicle and plug in hybrid electric vehicle conductive charge coupler	Requirements for charging modes which must be supported by the charging station: <ul style="list-style-type: none"> • SAE AC-Level2 - AC charging • SAE DC-Level2 - DC charging 	

Supply Station Standards

Document Number	Title	Content	Comments
IEC 61851-1	Part 1: General requirements for Electric vehicle conductive charging system	General requirements for charging electric road vehicles at standard a.c. supply voltages up to 1.000V and at d.c. voltages up to 1.500V, and for providing electrical power for any additional services on the vehicle if required when connected to the supply network.	
IEC 61851-21	Part 21: Electric vehicle requirements for conductive connection to an AC/DC supply	Requirements only to on-board circuits with the following maximum working voltages: For a.c. voltages up to 1.000V and for d.c. voltages up to 1.500 V. This includes tests on the complete vehicle with the charging system installed and tests on the charging system as a component.	
IEC 61851-22	Part 22: AC electric vehicle charging station	Requirements for a.c. electric vehicle charging stations for conductive connection to an electric vehicle, with a.c. supply voltages according up to 1.000V.	
IEC 61851-23	Part 23: DC electric vehicle charging station	Requirements for d.c. electric vehicle charging or supply stations for conductive connection to the vehicle, with an a.c. or d.c. input voltage, up to 1.000V a.c. and up to 1.500V d.c..	<ul style="list-style-type: none"> • Temperature monitoring is mandatory • Connector is to be used in an ambient temperature of between -30 °C and +50 °C

Standards

Under review and may be shifted to the CCS umbrella document

Vehicle Standards

Document Number	Title
ISO 6469-3	Electric road vehicles - Safety specifications - Part 3: Protection of persons against electric hazards
ISO 17409	Electrically propelled road vehicles - Connection to an external electric power supply - Safety requirements

Communication Standards

Document Number	Title	Content
ISO/IEC 15118-1	Road vehicles — Vehicle to grid communication interface – Part 1: General information and use-case definition	General information about the communication and usecase definition between electric vehicles and the electric vehicle supply equipment
ISO/IEC 15118-2	... Part 2: Network and application protocol requirements	Technical Protocol description and open systems interconnections (OSI) layer requirements
ISO/IEC 15118-3	... Part 3: Physical and data link layer requirements	Wired physical and data link layer requirements for a high level communication
ISO/IEC 15118-4	... Part 4: Network and application protocol conformance test	Standard in process
DIN SPEC 70121	Electromobility - Digital communication between a d.c. EV charging station and an electric vehicle for control of d.c. charging in the Combined Charging System	Defines communication between the EVSE and EV with regard to d.c. charging with EIM.
IEC 61851-24	Electric vehicle conductive charging system - Part 24: Control communication protocol between off-board DC charger and electric vehicle	Requirements for digital communication between a d.c. EV charging station and an electric vehicle for control of d.c. charging, with an a.c. supply input voltages up to 1.000V and d.c. output voltages up to 1.500V for the conductive charging procedure
IEC 61850	Communication Networks and Systems in Substations	General and specific functional requirements for provide interoperability between the intelligent electronic devices for protection, monitoring, metering, control and automation in substations
NAR pendant:		
SAE J2847	Communication between Plug-in Vehicles and...	<ul style="list-style-type: none"> the Utility Grid, the supply Equipment, the Utility Grid for Reverse Power Flow and for Diagnostic Communication for Plug-in Vehicles
SAE 2931	Inband Signaling Communication for Plug-in Electric Vehicles	Requirements for digital communication between Plug-in Vehicles, the Electric Vehicle Supply Equipment and the utility or service provider, Energy Services Interface, Advanced Metering Infrastructure and Home Area Network.

General Standards

Document Number	Title
IEC 61439-7	Low-voltage switchgear and control gear assemblies - Part 7
IEC 60038	IEC standard voltages
IEC 61000-4-4	Electromagnetic compatibility (EMC) - Part 4-4: Testing and measurement techniques - Electrical fast transient/burst immunity test
IEC 61000-4-5	Electromagnetic compatibility (EMC) – Part 4-5: Testing and measurement techniques – Surge immunity test
IEC 61000-4-6	Electromagnetic compatibility (EMC) - Part 4-6: Testing and measurement techniques - Immunity to conducted disturbances, induced by radio-frequency fields
IEC 61000-4-11	Interpretation sheet 1 - Electromagnetic compatibility (EMC) - Part 4-11: Testing and measurement techniques - Voltage dips, short interruptions and voltage variations immunity tests
IEC 61557-8	Electrical safety in low voltage distribution systems up to 1.000V AC and 1.500V DC - Equipment for testing, measuring or monitoring of protective measures - Part 8: Insulation monitoring devices for IT systems
Noise TA	Technical instructions for noise protection
IEC 61000-6-1	Electromagnetic compatibility (EMC) - Part 6-1: Generic standards - Immunity for residential, commercial and light-industrial environments
IEC 60529	Degrees of protection provided by enclosures (IP Code)
IEC 60364-7-722	Low voltage electrical installations: Part 7-722: Requirements for special installations or locations - Supply of Electric vehicle
NAR and German pendant:	
SAE J1766	Recommended Practice for Electric and Hybrid Electric Vehicle Battery Systems Crash Integrity Testing
DIN EN 50160	Voltage characteristics of electricity supplied by public distribution networks